

# Environment & Health Protection Guidelines



**On-site**

**Sewage**

**Management**

**for**

**Single**

**Households**

ENVIRONMENT & HEALTH PROTECTION GUIDELINES

# On-site Sewage Management for Single Households

January 1998



**NSW HEALTH**



**Department of Urban  
Affairs and Planning**

## STATE GOVERNMENT OFFICES

The following Departments contributed to the development of these guidelines. Further copies may be obtained from the Department of Local Government. All enquiries should be directed to the nearest regional office of the appropriate Department, listed in the "Further Information" Section at the back of the guidelines.

### DEPARTMENT OF LOCAL GOVERNMENT

Locked Bag 1500  
BANKSTOWN 2200  
ph: (02) 9793 0793  
fax: (02) 9793 0799

### ENVIRONMENT PROTECTION AUTHORITY

Locked Bag 1502  
BANKSTOWN 2200  
ph: (02) 9795 5000  
fax: (02) 9795 5002  
Pollution Line  
131 555 or (02) 9325 5555

### DEPARTMENT OF HEALTH

PO Box 798  
GLADESVILLE 2111  
ph: (02) 9816 0373

### DEPARTMENT OF LAND AND WATER CONSERVATION

GPO Box 39  
SYDNEY 2001  
ph: (02) 9372 7468  
fax: (02) 9372 7488

### DEPARTMENT OF URBAN AFFAIRS AND PLANNING

GPO Box 3927  
SYDNEY 2001  
ph: (02) 9391 2000

### Disclaimer

This document is a compendium of information and useful guidelines. Every reasonable effort has been made to give reliable data and information. Readers should not act or rely on this publication as their sole source of information without taking into consideration their particular circumstances.

**ISBN:** 0 7310 9496 4

### Copyright

This work is copyright. The Copyright Act 1968 permits fair dealing for study, research, news reporting, criticism or review. Selected passages, tables or diagrams may be reproduced for such purposes provided acknowledgment of the source is included.

### Printing

Printed using recycled paper. Design and Layout by Facelift Design, Ph: 02 - 4268 1919.

## FOREWORD

Effective management of domestic sewage and wastewater is an important consideration for the health of communities and the environment. It requires the active involvement of many stakeholders, including NSW Government agencies, local councils, land developers, industry and householders.

These guidelines have been developed as part of a NSW Government commitment to a consistent and comprehensive approach to the use of small septic tanks and other on-site sewage management systems. The approach taken is based on the need to protect and enhance public health and the environment. On-site sewage management policies for single households have been developed, and information has been provided on how to implement them.

To help develop these guidelines a working group of Government agencies was formed, consisting of the NSW Department of Local Government, the NSW Environment Protection Authority, the NSW Department of Health, the NSW Department of Land and Water Conservation, and the NSW Department of Urban Affairs and Planning. A program of public consultation was also undertaken to ensure that all major environmental and health protection issues were considered.

Effective water cycle management is a critical factor for long-term sustainable use of land and other natural resources. These guidelines focus on on-site sewage management within the scope of local government responsibilities, and encourage each council to develop an on-site sewage management strategy for its own area that incorporates appropriate regional and catchment management objectives. A strategic approach to sewage management planning will facilitate the long-term sustainable use of residential land and will ensure that the cumulative and site-specific effects of wastewater are thoroughly assessed and managed.



While these guidelines aim to assist local councils in the regulation of small on-site sewage management systems, they also provide general guidance to other stakeholders such as developers and householders.

Implementing these guidelines will improve the environmental quality and health of those communities that rely on on-site sewage management.

# TABLE OF CONTENTS

<b>INTRODUCTION</b>	9
ON-SITE SEWAGE MANAGEMENT OBJECTIVE	10
SUPPORTING PRINCIPLES	12
SUPPORTING POLICIES, STRATEGIES AND GUIDELINES	16
PERFORMANCE OBJECTIVES	16
USING THESE GUIDELINES	17
<b>SECTION 1 REGULATION</b>	19
1.1 LEGISLATION	21
1.1.1 Local Government Legislation	21
1.1.2 Other Legislation	23
1.2 DEVELOPMENT PLANNING	23
1.2.1 Rural Residential Release Strategies	26
1.2.2 Local Environmental Plans	27
1.2.3 Development Control Plans	28
1.2.4 Development Applications - Subdivision	29
1.2.5 Development Applications - Dwellings	29
<b>SECTION 2 ON-SITE SEWAGE MANAGEMENT STRATEGIES</b>	31
2.1 INTRODUCTION	33
2.2 DEVELOPING AN ON-SITE SEWAGE MANAGEMENT STRATEGY	34
<b>SECTION 3 OPERATIONAL STRATEGIES</b>	41
3.1 REGULATING ON-SITE SEWAGE MANAGEMENT SYSTEMS	43
3.2 LOCAL POLICY REQUIREMENTS FOR ON-SITE SYSTEMS	44
3.3 ENVIRONMENTAL AUDITS, MONITORING AND REPORTING	45
3.4 EDUCATION AND TRAINING	46
3.5 RESPONSIBILITIES OF OTHER STAKEHOLDERS	49
<b>SECTION 4 EVALUATING THE SITE</b>	53
4.1 INTRODUCTION	55
4.2 THE BROAD EVALUATION - DESKTOP STUDY	57
4.3 THE SITE AND SOIL ASSESSMENT	59
4.3.1 Assessing for Subdivisions	59
4.3.2 Assessing for Single Lots	61
4.3.3 Site Features	62
4.3.4 Soil Features	67
4.4 THE SITE REPORT	73
<b>SECTION 5 ON-SITE SEWAGE MANAGEMENT SYSTEM OPTIONS</b>	75
5.1 INTRODUCTION	77
5.1.1 Minimising Wastewater Generation	77
5.1.2 Characteristics of Untreated Domestic Wastewater	77

5.1.3	The Three Phases of Wastewater Management	80
5.2	TOTAL ON-SITE MANAGEMENT	82
5.3	ON-SITE TREATMENT SYSTEMS	82
5.3.1	General Considerations	82
5.3.2	Septic Tanks - Septic Closets - Collection Wells	84
5.3.3	Aerated Wastewater Treatment Systems (AWTS)	90
5.3.4	Waterless Composting Toilets	96
5.3.5	Recirculating Aerobic Sand Filter Devices (RASFD)	100
5.3.6	Wet Composting Toilets	101
5.3.7	Combustion Toilets	104
5.3.8	Ancillary Systems	105
5.3.9	Greywater Treatment Devices	107
5.3.10	Disinfection	108
5.4	ON-SITE LAND APPLICATION SYSTEMS	111
5.4.1	General Considerations	111
5.4.2	Irrigation	115
5.4.3	Soil Absorption	119
5.5	PARTIAL ON-SITE MANAGEMENT	121
5.5.1	Common Effluent Systems (CES)	121
5.5.2	Chemical Toilets	123
5.5.3	Pump-Out Systems	124
5.5.4	Wastewater Ejection Units	126
5.6	TOTAL OFF-SITE SEWAGE MANAGEMENT	127
<b>SECTION 6</b>	<b>SELECTING AN ON-SITE SEWAGE MANAGEMENT SYSTEM</b>	<b>129</b>
6.1	INTRODUCTION	131
6.2	IMPORTANT CONSIDERATIONS	131
6.2.1	General	131
6.2.2	Climate	132
6.2.3	Waste Streams	133
6.2.4	System Combinations	134
	<b>APPENDICES AND FURTHER INFORMATION</b>	<b>137</b>
	<b>APPENDIX 1: On-site Sewage Management Strategy Checklist</b>	<b>139</b>
	<b>APPENDIX 2: Model Site Report</b>	<b>144</b>
	<b>APPENDIX 3: Model Septic Tank &amp; Pump-out Conditions of Approval</b>	<b>148</b>
	<b>APPENDIX 4: Model AWTS Conditions of Approval</b>	<b>150</b>
	<b>APPENDIX 5: Model Composting Toilet Conditions of Approval</b>	<b>151</b>
	<b>APPENDIX 6: Estimating Irrigation Area Size &amp; Wetweather Storage Requirements</b>	<b>152</b>
	<b>APPENDIX 7: Vegetation Suitable for Land Application Areas</b>	<b>166</b>
	<b>APPENDIX 8: Public Information Brochures</b>	<b>169</b>
	<b>GLOSSARY</b>	<b>181</b>
	<b>BIBLIOGRAPHY</b>	<b>186</b>
	<b>FURTHER INFORMATION</b>	<b>189</b>

## LIST OF FIGURES

Figure 1:	Management cycle of continuous improvement	17
Figure 2:	Cross-Section of a Septic Tank	85
Figure 3:	Cross-Section of a Suspended Growth AWTS	91
Figure 4:	Cross-Section of a Single Chamber Waterless Composting Toilet	97
Figure 5:	Cross-Section of a Wet Composting Toilet	102

## LIST OF TABLES

Table 1:	Planning Process - Key Stages and Recommended Levels of Assessment	25
Table 2:	Example Performance Indicators for the OSMS	38
Table 3:	Basic Knowledge and Awareness Required by Stakeholders	47
Table 4:	Site Assessment: Rating for On-site Systems	63
Table 5:	Recommended Buffer Distances for On-site Systems	66
Table 6:	Soil Assessment Rating for On-site Systems	68
Table 7:	Soil Tests Required for Different Situations	69
Table 8:	Soil Permeability Categories Based on Soil Texture and Structure	71
Table 9:	Characteristics of Typical Untreated Domestic Wastewater	80
Table 10:	On-site Sewage Management Systems	81
Table 11:	Expected Quality of Wastewater after Treatment in a Septic Tank	86
Table 12:	Criteria used for Calculating the Capacity of Domestic Septic Tanks	88
Table 13:	Characteristics of Domestic Septage	89
Table 14:	Expected Quality of Wastewater after Treatment in an AWTS	92
Table 15:	Degree of Treatment Needed for Land Application	111
Table 16:	On-site System Combinations	135

## ABBREVIATIONS

<b>AS</b>	Australian Standard
<b>AWTS</b>	aerated wastewater treatment system
<b>BA</b>	building application
<b>BOD</b>	biochemical oxygen demand
<b>CES</b>	common effluent system
<b>cfu</b>	colony forming unit
<b>DA</b>	development application
<b>DCP</b>	development control plan
<b>DLG</b>	NSW Department of Local Government
<b>DLWC</b>	NSW Department of Land and Water Conservation
<b>dS/m</b>	deciSiemens per metre
<b>DUAP</b>	NSW Department of Urban Affairs and Planning
<b>EC</b>	electrical conductivity
<b>EPA</b>	NSW Environment Protection Authority
<b>fc</b>	faecal coliform
<b>GIS</b>	geographic information systems
<b>HWSF</b>	human waste storage facility
<b>HWTD</b>	human waste treatment device
<b>LEP</b>	local environmental plan
<b>LES</b>	local environmental study
<b>LGA</b>	local government area
<b>LOP</b>	local orders policy
<b>NSW Health</b>	NSW Department of Health
<b>NWQMS</b>	National Water Quality Management Strategy
<b>on-site system</b>	on-site sewage management system
<b>OSMS</b>	on-site sewage management strategy
<b>RASFD</b>	recirculating aerobic sand filter device
<b>REP</b>	regional environmental plan
<b>SAR</b>	sodium adsorption ratio
<b>SS</b>	suspended solids
<b>SVI</b>	sludge volume index
<b>TN</b>	total nitrogen
<b>TP</b>	total phosphorus
<b>WC</b>	water closet





# INTRODUCTION

These guidelines have been developed to help local councils assess, regulate and manage the selection, design, installation, operation and maintenance of single household on-site sewage management systems. The guidelines may also be useful to householders, developers and others.

The guidelines aim to promote ecologically sustainable development, protection of the environment, protection of public health and protection of community amenity.

These guidelines address the environmental and public health performance requirements of on-site systems (including the on-site component of partial on-site systems). They also provide administrative and technical guidance on the steps that should be taken to ensure that on-site systems comply with these requirements in the long term.

The guidelines provide advice on: planning; site evaluation; system selection; system operation and maintenance; and ongoing system management, for on-site systems treating up to 2000 litres of wastewater a day.

The guidelines discuss:

- the range of on-site treatment systems available
- methods of applying treated wastewater to land.

The guidelines do not cover:

- costs of systems
- off-site management systems
- on-site sewage management systems for more than a single household or for commercial and industrial premises
- the separate management of greywater in a sewered area.

This document is a set of guidelines; it is not a design and operations manual. It provides guidance on possible ways to meet environmental and health outcomes.

The guidelines focus on new developments on land that has not previously been subdivided. However, they can also provide useful information when assessing other situations (including undeveloped land within previously subdivided areas) or when renewing existing systems. If an alternative approach or existing situation conflicts with these guidelines, options other than those outlined might be acceptable, providing that they meet the performance objectives described on page 16, and satisfy the requirements of all relevant statutory authorities.

## ON-SITE SEWAGE MANAGEMENT OBJECTIVE

There has been increasing concern that on-site sewage management systems have failed to satisfy the expectations of unsewered communities in New South Wales. Growing evidence suggests that many of these systems do not meet environmental and public health requirements.

To enable public health and environment protection requirements to be met, land use planning for residential development needs to draw on the principles of ecologically sustainable development (ESD), total catchment management (TCM), water cycle management, and the protection of public health. If these principles are applied, the cumulative and incremental impacts of on-site sewage management can be assessed and mitigated.

These four principles have been considered in formulating the objective for these guidelines, which is:

**to guide communities in New South Wales towards sustainable on-site management of domestic sewage and wastewater while protecting and enhancing the quality of public health and the environment in the long term**

To help meet this objective, these guidelines encourage a systematic approach to land use planning, site assessment, and the selection, design and operation of on-site systems for sustainable management.

Local councils are encouraged to develop strategies for domestic sewage management as part of the Local Government Act management planning processes for council services and the Environmental Planning and Assessment Act planning processes for land use controls. Such strategies need to incorporate a management approach of continual improvement, addressing issues such as:

- incorporating sewage management considerations in the early stages of the environmental assessment and land use planning process
- considering all sewage management options
- the impact of on-site sewage management on a catchment or regional basis
- the commitment, responsibilities and education of a range of stakeholders, including local government, service providers, land developers and householders
- site-specific evaluation and assessment
- appropriate selection, design and construction of on-site sewage management facilities based on circumstances and site constraints
- ongoing maintenance and proper operation of installed systems
- initiation of a monitoring and review program.

The *Local Government Act 1993* and the *Environmental Planning and Assessment Act 1979* provide councils with the legislative framework needed to implement these strategies.

On-site sewage management systems and centralised sewerage systems should be compared on the basis of ecological sustainability and public health impacts, and the full range of benefits and constraints should be taken into account.

Centralised sewerage systems are usually the best method of sewage management in urban areas and in rural residential areas where a council water supply is available. This is because there is generally insufficient land to sustainably manage all the wastewater in these areas. Centralised systems are also the most suitable in regions with site constraints such as high rainfall, restrictive topography, or poor or shallow soils. Centralised systems can be built to service from less than 10 to many thousands of households. Ideally all wastewater, or that portion that cannot be safely diverted and re-used on site, is conveyed to a centralised facility, where it is treated to a level suitable for re-use or return to the environment in a sustainable manner.

On-site sewage management systems are more suitable in areas with few of the above site constraints and where there is sufficient available land to ensure systems can be operated in a sustainable manner. However, poorly planned and/or poorly maintained on-site sewage management systems can increase the potential for diffuse source pollution of waterways, groundwater and adjoining land, and can increase the risk of exposure to pathogens. Householders, service agents and local councils should take responsibility for monitoring performance and ensuring that pollution and health risks do not arise.

Consequently, on-site sewage management should not be seen as a cheap or easy alternative to a centralised sewerage system.

If on-site sewage management is determined to be the best long-term option for an area, appropriate development standards, including minimum lot sizes, should be established before the land is released. When setting the development standards, factors such as climate, soil, geography, environmental sensitivity, and risks to public health should be taken into account.



An EPA model has been developed for estimating land requirements for effluent irrigation, based on eliminating impacts on soils, waters, and public health (NSW Environment Protection Authority 1995). Assessments with the model in many areas of the State have shown that new subdivisions for residential development involving on-site sewage management require a minimum of 4000 - 5000 m<sup>2</sup> total area per household to reduce impacts in the medium to long term.

Site characteristics are key issues in planning subdivisions and choosing on-site sewage management systems. Appropriate levels of site assessment will be needed during the planning, system selection and system design stages. Information on site characteristics will be an important component of the decision making process, and because of this, site evaluation needs to be done by suitably qualified staff.

Finally, management of sewage on-site should not be seen as the simple disposal of an unwanted nuisance. Wastewater, including the nutrients and organic matter it contains, should be managed appropriately and used wherever possible.

## SUPPORTING PRINCIPLES

On-site sewage management involves the treatment of wastewater followed by the release of liquid (treated wastewater) and solid (sludge, septage and compost) products into the environment. Inappropriate use or disposal of these products can have adverse impacts such as:

- the spread of disease by bacteria, viruses, parasites and other organisms in the wastewater
- contamination of groundwater and surface water
- degradation of soil and vegetation
- decreased community amenity, caused by odours, noise and insects.

Considerable effort has been made by the NSW Government to define how wastewater can be managed to ensure adequate and long-term environment and health protection. Although there are clear regional differences in how this may be achieved, there are principles for sewage management, the environment and health that underpin this process. The sewage management principles are:

**1. Performance outcomes.** We need to consider the wider environmental outcomes of sewage management decisions. Historically, the focus of sewage management has been on engineering design of sewerage systems and less consideration has been given to the environmental impacts caused by discharging wastewater to the environment. The realisation is that there is an increasing need to develop sewage management strategies that are consistent with other policy initiatives for protecting both land and water resources and public health, preferably on a catchment-wide basis.

**2. Appropriate treatment.** The level of sewage treatment required depends not only on the nature and sensitivity of the receiving environment, but also on the potential uses of the treated wastewater and biosolids.

**3. Productive re-use of wastewater components.** Many of the components of treated wastewater and biosolids can be used as valuable resources if managed wisely. These components include water, and nutrients such as nitrogen and phosphorus, which are in both treated wastewater and biosolids.

**4. Reliability.** It is inappropriate to install a sewage management facility and to expect it to perform adequately without proper supervision, maintenance and performance assessment.

**5. Long-term impacts.** It is inadequate to specify treatment systems, management practices, environmental monitoring or regulatory regimes that have short-term horizons. Degradation of the environment can be incremental or cumulative over time. The environmental and health principles underpinning the management of on-site systems include:

- ecologically sustainable development (ESD)
- water cycle management
- total catchment management (TCM)
- protection of public health and the prevention of public health risk.

The NSW Government supports the National Water Quality Management Strategy (NWQMS), which is a joint strategy of two Ministerial Councils: the Australian and New Zealand Environment and Conservation Council (ANZECC), and the Agricultural and Resource Management Council of Australia and New Zealand (ARMCANZ). The aim of the NWQMS is to pursue the sustainable use of the nation's water resources by protecting and enhancing their quality while maintaining economic and social development.

The NWQMS has identified key elements of a management approach for water quality. The policies and principles for managing diffuse source pollution particularly call for the adoption of best management practice. To implement best management practice effectively we need to use a range of policy instruments, including education, regulation and market-based measures. Strategies aimed mainly at changing practices can sometimes be indirect and imprecise, but managers need to have access to a range of instruments, and the flexibility to use them.

One of the main aims of these guidelines is to help local councils to address these environmental and health principles and programs through the development of effective management strategies. The main principles are discussed here to provide a working basis for developing performance objectives and to help those making decisions about on-site sewage management.

## ECOLOGICALLY SUSTAINABLE DEVELOPMENT (ESD)

There are many definitions of ESD. The one below conveys the meaning as used in these guidelines, and is from the Australian National Strategy for Ecologically Sustainable Development (Commonwealth of Australia 1992). ESD is:

**[development] using, conserving and enhancing the community's resources so that ecological processes, on which life depends, are maintained, and the total quality of life, now and in the future can be increased**

In NSW, the following four principles of ESD are stated in the *Protection of the Environment (Administration) Act 1991* [Section (6)(2), (a)-(d)]:

- **the precautionary principle** - if there are threats of serious or irreversible environmental damage, lack of full scientific certainty should not be used as a reason for postponing measures to prevent environmental degradation
- **intergenerational equity** - the present generation should ensure that the health, diversity and productivity of the environment is maintained and enhanced for the benefit of future generations
- **conservation of biological diversity and ecological integrity**
- **improved valuation and pricing of environmental resources**

The Local Government Act 1993 as amended by the Local Government Amendment (Ecologically Sustainable Development) Act 1997 requires that councils must have regard to the principles of ecologically sustainable development in carrying out responsibilities. A detailed definition of the 4 principles of ecologically sustainable development is provided in the Dictionary to the Local Government Act.

To achieve an ecologically sustainable approach, local councils need to build these four principles into all decisions about on-site sewage management.

## WATER CYCLE MANAGEMENT

Water cycle management (sometimes called 'total water cycle management' or 'integrated water cycle management') is a comprehensive approach to managing water resources. It integrates all the natural and managed components of the water cycle into decision making.

Natural components of the water cycle include rainfall, rivers, oceans and groundwater, and the physical links between these, such as evapotranspiration, surface run-off and cloud movement.

Managed components of the water cycle include the supply of water for domestic, industrial, and agricultural purposes, and the treatment and release of sewage and stormwater.

On-site sewage management can potentially have an impact on the natural and managed parts of the water cycle through pollution of ground and surface waters with pathogens and nutrients. Any decisions about the on-site management of sewage should consider these impacts.

## TOTAL CATCHMENT MANAGEMENT (TCM)

TCM (often simply called 'catchment management') involves the coordinated and sustainable use and integrated management of land, water, vegetation and other natural resources on a water catchment basis.

A basic element of total catchment management is the need for all 'stakeholders' within a catchment to participate actively. Local councils should work closely with catchment management committees, industry and the local community. Local councils should consider the implications of providing and managing wastewater services on a catchment-wide basis.

The publication *Incorporating the Principles of TCM into Land Use Planning* (DUAP - SCMCC, 1996) gives guidance to councils on how to carry out land use planning on a catchment basis.

## PROTECTION OF PUBLIC HEALTH AND PREVENTION OF PUBLIC HEALTH RISK

Two major driving forces behind water management have had a significant impact on public health, as shown by the decrease in mortality and morbidity rates and corresponding increase in life expectancy this century. These two driving forces are:

- the provision of an adequate and safe public water supply through catchment management and protection, water treatment and disinfection, and distribution to each household
- the removal of human waste products using a reticulation and transfer system for separate sanitary management.

Because water is a precious resource that is having increasing population demands placed on it, the future trend is towards greater wastewater use and re-use. However, this must not be achieved at the expense of public health. It is essential that wastewater use and re-use is practised and managed wisely, with a view toward maintaining the public health standards expected by the community. Thorough, well-designed and rigorous management practices will help to minimise potential public health risks.

Local councils and community organisations need to understand the public health risk in the decisions made and options chosen for household on-site sewage management.



## SUPPORTING POLICIES, STRATEGIES & GUIDELINES

These guidelines have not been developed in isolation. They are part of the Government's strategy for sewage management in NSW. Various additional reference documents may complement or be complemented by these guidelines. They include:

- the local council's own policies and guidelines for its particular area
- other government regulations, guidelines and policies (for example, State Environmental Planning Policies and NSW Health Certification Guidelines for human waste treatment devices)
- relevant technical references (see Bibliography)
- relevant Australian Standards (see Bibliography)
- the National Water Quality Management Strategy, published by the Australian and New Zealand Environment and Conservation Council (ANZECC 1992)
- various government initiatives, such as uniformity on plumbing and drainage regulation and the Country Towns Water, Sewerage and Drainage Program (DLWC 1996). (A program under which the NSW Government provides technical, management and financial support to local councils in country areas. It is administered by DLWC.)

## PERFORMANCE OBJECTIVES

Performance objectives have been formulated to help make sure that on-site sewage management for single households is appropriate and will not affect public health or the environment. When considering using any on-site sewage management system, particular attention should be paid to the cumulative effects of multiple systems operating within a catchment, and within the wider environment.

On-site sewage management systems should meet the following environmental and health performance objectives over the long term:

- **prevention of public health risk** - sewage contains bacteria, viruses, parasites and other disease-causing organisms. Contact with effluent should be minimised or eliminated, particularly for children. Residuals, such as composted material, should be handled carefully. Treated sewage should not be used on edible crops that are consumed raw
- **protection of lands** - on-site sewage management systems should not cause deterioration of land and vegetation quality through soil structure degradation, salinisation, waterlogging, chemical contamination or soil erosion
- **protection of surface waters** - on-site sewage management systems should be selected, sited, designed, constructed, operated and maintained so that surface waters are not contaminated by any flow from treatment systems and land application areas (including effluent, rainfall run-off and contaminated groundwater flow)

- **protection of groundwaters** - on-site sewage management systems should be selected, sited, designed, constructed, operated and maintained so that groundwaters are not contaminated by any flow from treatment systems and land application areas
- **conservation and reuse of resources** - the resources in domestic wastewater (including nutrients, organic matter and water) should be identified and utilised as much as possible within the bounds posed by the other performance objectives; water conservation should be practiced and wastewater production should be minimised
- **protection of community amenity** - on-site sewage management systems should be selected, sited, designed, constructed, operated and maintained so that they do not unreasonably interfere with quality of life, and, where possible, so that they add to the local amenity - special consideration should be given to aesthetics, odour, dust, vectors and excessive noise.

## USING THESE GUIDELINES

These guidelines consist of two major parts. Sections 1, 2, and 3, reflect a typical cyclical management model of continuous improvement, as illustrated in Figure 1. The factors and issues affecting on-site sewage management are defined, strategies and plans for on-site sewage management are developed and implemented, installed on-site sewage management systems are periodically monitored and the management strategy reviewed. The process may then be repeated using the information from the review to update and improve the management process wherever necessary.

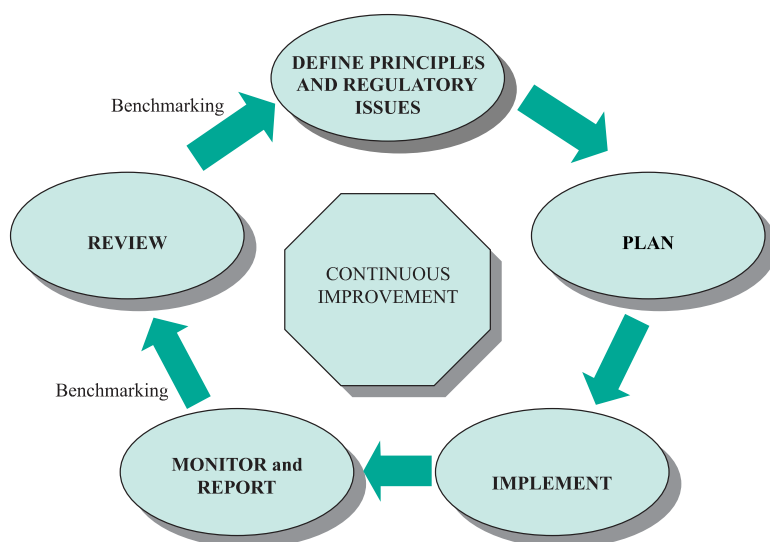

Figure 1: Management cycle of continuous improvement (adapted from DLWC 1997a)

Sections 4, 5, and 6, provide guidance on site evaluation, treatment and application systems, and the selection of an on-site sewage management system for a specific site. These sections will be updated from time to time as knowledge or issues change.





## **Section One**

# **Regulation**

## 1.1 LEGISLATION

### 1.1.1 LOCAL GOVERNMENT LEGISLATION

On-site sewage management is a fundamental aspect of the environmental assessment, land use planning and development control functions of local councils under the Environmental Planning and Assessment Act, 1979 and councils' building control functions under the Local Government Act 1993.

When determining applications for subdivision, development or building approval local councils are required to consider whether existing utility services are adequate for the intended use and if not, whether suitable arrangements for on-site sewage management will be made.

It is recommended that appropriate on-site sewage management requirements for environment and health protection should be specified by the council at the earliest practical stage of the council's land use planning and local policy development processes.

The design, installation and operation of domestic on-site sewage management systems are regulated under local government legislation. Under the Local Government Act (section 68), council approval is needed for the installation, construction or alteration of a human waste treatment device or storage facility and a drain connected to it. From 1 July 1998, council approval will also be needed for the ongoing operation of an on-site sewage management system. Failure to get approval or to comply with the conditions of approval are offences punishable by fines of up to 20 penalty units.

The Local Government (Approvals) Regulation 1993 sets out specific requirements for on-site sewage management approvals, including matters for council consideration, performance standards and circumstances where prior council approval is not required. Part 3 of the Regulation has recently been amended to incorporate new performance standards consistent with these guidelines and to introduce a new requirement for approval to operate a domestic on-site sewage management system.

NSW Health is responsible for accrediting human waste treatment devices or human waste storage facilities that are intended to receive domestic wastewater or human waste. Accreditation is mandatory for commercially manufactured units and for commercially distributed standard designs of the types specified in the regulations. The accreditation system provides a centralised assessment and testing procedure. A certificate of accreditation might include specific requirements for the installation, operation and maintenance of the tested system. Such conditions become conditions of council approval. Accreditation is not required for a human waste treatment device installed as a prototype for research, development or testing purposes, nor for a special purpose system designed for a single application, nor for an owner-built system constructed to an individual design. In such cases, general criteria apply and assessment is a matter for the local council.

Whether or not an accredited human waste treatment device is to be incorporated in the design, the local council is responsible for site assessment and for determining the overall suitability of on-site sewage management arrangements for a particular site. These guidelines set out technical details and performance standards for public health and environment protection that should be considered by the local council in assessing applications for approval. The local council can take into consideration a range of other published standards and information that might be relevant in a particular case. The local council is also responsible for monitoring the operation of all existing domestic on-site sewage management systems and ensuring that those systems always comply with relevant performance standards.

In addition to the approval responsibilities discussed above, section 124 of the *Local Government Act 1993* gives the council power to issue orders requiring a person:

- to comply with an approval (Order 30)
- to take action to maintain premises in a healthy condition (Order 21)
- to store, treat or dispose of waste (Order 22)
- not to use or permit a human waste storage facility to be used (Order 25)
- to connect premises to a public sewer when the sewer is within 75 metres (Order 24).

Orders can be given to the owner or occupier of the premises or to the person responsible for the waste or the container in which the waste is stored. Failure to comply with such an order is an offence punishable by a fine of up to 20 penalty units.

The Department of Local Government recommends that every local council prepares an on-site sewage management strategy (OSMS) for its area. As a minimum, such a strategy should include:

- a statement of on-site sewage management policy
- a statement of the on-site sewage management goals for particular areas and catchments
- a statement of the programs the council has established or proposes to establish to meet those goals
- a statement outlining the on-site sewage management response procedures the council will implement in emergencies
- a statement of the on-site sewage management performance monitoring and measurement program the council will implement
- a statement of the council's commitment to the continuing improvement of on-site sewage management in its area.

Councils have a specific responsibility under local government legislation to maintain a register of the approvals granted, including those granted for on-site sewage management systems. The register should show the address of the premises, details of the system, and any conditions attached to the approval. Councils must also prepare annual updates of State of the Environment reports for their areas, showing details of polluted areas and on-site sewage management policies. The performance of on-site sewage management systems and the cumulative impact of those systems on catchments within the council's area are issues that should be addressed in the State of the Environment report.

### 1.1.2 OTHER LEGISLATION

The Minister for Health has power under the *Public Health Act 1991* to issue orders if the health of the public is likely to be at risk. The Minister for Health may also direct public authorities to take action to stop public health being endangered.

Polluting waters or permitting waters to be polluted are offences against the *Clean Waters Act 1970*. If such breaches occur, the EPA or councils can issue a penalty notice ('on-the-spot-fine') or start a prosecution under the *Environmental Offences and Penalties Act 1989*. The owner or occupier of premises who permits a discharge to waters, including groundwater, will be in breach of the *Clean Waters Act 1970* unless the discharge is in accordance with a pollution control licence issued by the EPA.

Under Clause 11A of the Clean Waters Regulation 1972, the EPA has responsibility for approving and licensing waste management facilities installed on premises used for commercial and industrial purposes, or on residential premises normally occupied and used by more than a single household.

It is the **responsibility of the owner or occupier of premises** to ensure that on-site systems are designed, installed and managed so that pollution of groundwater or surface waters does not occur, and so that there is no risk to public health, safety and the environment from the operation of an on-site sewage management system.

## 1.2 DEVELOPMENT PLANNING

Development and land use can have impacts beyond the physical boundaries of a site. The various phases of land use planning and development offer a number of opportunities to minimise the impacts of human activity on the environment.

These guidelines use a strategic planning approach to establish requirements for on-site sewage management on a geographic area, LGA, catchment or regional basis, rather than attempting to specify prescriptive standards on a state-wide basis.



Local councils are encouraged to prepare and implement an on-site sewage management strategy (OSMS) for their LGA. An OSMS will assist councils in ensuring that on-site sewage management issues are considered during all phases of land use and development planning. The OSMS provides, among other things, information on land use planning and development, proposals for on-site sewage management services, and council funding programs. More information on OSMSs is included in Section 2 and Appendix 1.

The capacity of the land to sustain on-site sewage management should be considered at the earliest possible phase in the planning process. Land that is seriously limited in its capacity to manage sewage should be identified at the outset to prevent inappropriate development. If not, development can have public health and environmental implications, and expectations regarding issues such as development densities can also result in conflict between developers and local councils.

The most appropriate technology for on-site sewage management should be determined as early as possible, as this choice can have similar implications.

Traditionally there have been three separate but related phases in the planning process under the *Environmental Planning and Assessment Act 1979* where on-site sewage management is considered:

- when a local environmental plan/local environmental study (LEP/LES) is prepared to zone or rezone land. This may be accompanied by a development control plan (DCP), which specifies more detailed requirements for on-site sewage management. Typically, the rezoning of rural land for a residential use is the activity that has the greatest potential for concern regarding effective on-site sewage management
- when a development application (DA) is submitted for the subdivision of land, or
- when a DA is submitted for the construction of an individual dwelling on an allotment of land after subdivision.

A building application (BA) under the *Local Government Act 1993* is also required for dwellings in rural areas. Individual on-site sewage management systems are usually approved at the same time that the BA is approved.

The Government is currently pursuing an Integrated Development Assessment initiative involving a better organised and simplified development assessment process under the *Environmental Planning and Assessment Act*. This will streamline the level of assessment required at the individual dwelling level by combining development and building applications. The reforms will come into effect on 1 July 1998.

The LEP/LES stage has in the past been the earliest formal stage in the planning process when consideration of on-site sewage management has occurred. Increasingly however, the Department of Urban Affairs and Planning (DUAP) is requiring local councils to prepare rural residential release strategies before decisions are made to prepare LEPs to rezone rural land for residential use.

Table 1 indicates the different stages in the planning/development process when the issue of on-site sewage management should be addressed. It shows the level of assessment considered appropriate for each stage and the primary purposes of each level of assessment. The different stages of the planning process are discussed in detail below.



**Table 1: Planning Process - Key Stages and Recommended Levels of Assessment**

Stage in Planning Process	Possible Scales	Level of Assessment Required	Purpose
Rural residential release strategy	<ul style="list-style-type: none"> <li>• catchment-wide (prepared by multiple adjoining local councils)</li> <li>• multiple LGAs (local government areas)</li> <li>• one LGA</li> <li>• part of an LGA</li> </ul>	<ul style="list-style-type: none"> <li>• broad evaluation</li> <li>• desktop analysis based on soil landscape maps, GIS (geographic information systems), reports, studies and local knowledge</li> <li>• representative testing of different soil landscape types (if necessary)</li> </ul>	<ul style="list-style-type: none"> <li>• determine broad suitability for on-site sewage management</li> <li>• determine whether individual on-site or centralised sewage management is preferred</li> <li>• eliminate areas not suitable for on-site sewage management or where technological solutions are cost prohibitive or ecologically unsustainable</li> <li>• assess practicality of sewerage where reticulated water exists or will be supplied or on-site sewage management is not feasible</li> </ul>
Local environmental plan/local environmental study	<ul style="list-style-type: none"> <li>• catchment-wide (prepared by multiple adjoining local councils)</li> <li>• multiple LGAs</li> <li>• one LGA</li> <li>• part of an LGA</li> <li>• specific site</li> </ul>	<ul style="list-style-type: none"> <li>• representative testing of different soil landscape types for comprehensive LEP</li> <li>• detailed site and soil assessment (see Section 4) for site-specific rezonings</li> </ul>	<ul style="list-style-type: none"> <li>• determine minimum and average lot sizes</li> <li>• identify appropriate treatment technologies and on-site sewage management methods</li> <li>• establish performance standards/criteria</li> </ul>
Development control plan	<ul style="list-style-type: none"> <li>• one LGA</li> <li>• part of an LGA</li> <li>• specific site</li> </ul>	<ul style="list-style-type: none"> <li>• as for LEPs</li> <li>• detailed site and soil assessment (see Section 4) if DCP is to define wastewater management areas</li> </ul>	<ul style="list-style-type: none"> <li>• identify appropriate treatment technologies and on-site sewage management methods</li> <li>• establish performance standards/criteria</li> <li>• define on-site sewage management locations</li> </ul>
Development application - subdivision	<ul style="list-style-type: none"> <li>• specific site</li> </ul>	<ul style="list-style-type: none"> <li>• detailed site and soil assessment (see Section 4) if not done at LEP stage</li> </ul>	<ul style="list-style-type: none"> <li>• determine appropriate density</li> <li>• select treatment/on-site sewage management method</li> </ul>
Development application - dwelling	<ul style="list-style-type: none"> <li>• individual lot</li> </ul>	<ul style="list-style-type: none"> <li>• site and soil assessment (see Section 4)</li> </ul>	<ul style="list-style-type: none"> <li>• indicate precise land application area(s) and reserve area(s) if required</li> </ul>

### 1.2.1 RURAL RESIDENTIAL RELEASE STRATEGIES

Rural residential release strategies are strategic level assessments of the demand for, and capacity of, an area to sustain residential development. They are currently required by DUAP on the North and South Coasts of NSW before the preparation of LEPs that convert rural land to a residential use. As a best practice approach, DUAP recommends that the requirement to prepare rural residential release strategies be extended to the rest of the State and has prepared a draft Direction under Section 117 of the *Environmental Planning and Assessment Act 1979* to ensure this occurs. Although residential release strategies are prepared for both urban and rural residential developments, rural residential developments are likely to be the most relevant to the issue of on-site sewage management.

Rural residential release strategies can be prepared for part of an LGA, an entire LGA, a number of adjoining LGAs, or all the LGAs that make up a particular catchment. They could also be prepared on a regional basis, spanning a number of catchments. A regional or catchment approach is preferred, as this enables residential development to be directed to the most suitable areas. It also allows the cumulative impacts of issues such as on-site sewage management to be assessed and managed more effectively.

While the broad scale at which strategies are prepared means it is unreasonable to do a detailed analysis, the following steps are recommended:

- desktop analysis based on available information such as soil landscape maps, GIS (geographic information systems), reports, studies and local knowledge
- representative testing of different soil types (as identified using soil landscape maps or other larger scale mapping)
- identification of environmental and climatic constraints
- an analysis of opportunities for connecting to some form of centralised sewerage system, such as a common effluent system (CES).

When the rural residential release strategy has been prepared, the land might be classified in one of the following ways:

- unsuitable for on-site sewage management. In such cases, either connection to some form of centralised sewerage system or an acknowledgment that the land is unsuitable for development will be required
- suitable for on-site sewage management but with a number of identified limitations, for example, seasonally high rainfall or proximity to significant environmental features. In these cases, more detailed analysis might be required to identify on-site sewage management options or to ascertain whether there is a need for connection to a centralised sewerage system.

- suitable for on-site sewage management with minimal constraints. In such cases, it might be necessary to look further at whether individual on-site sewage management is preferred or whether a centralised sewage management option, a package treatment plant or common effluent system is desired

Although on-site sewage management is only one of the issues to be addressed in a rural residential release strategy, it is an issue that will have major implications for the amount and location of land released and the resultant minimum lot sizes.

A rural residential release strategy should identify areas for future development that can adequately meet on-site sewage management requirements without the need for major soil amendment, or that can be sewered economically. As a general principle, land provided with a reticulated water supply should also be capable of being sewered or serviced by a centralised sewerage system as part of its urban water services. Local councils in country NSW may contact their regional Department of Land and Water Conservation (DLWC) office regarding assistance in the development of appropriate and affordable sewerage services in urban areas under the Country Towns Water, Sewerage and Drainage Program (DLWC 1996).

The approach adopted by DUAP on the North Coast, which emphasises the need for rural residential development to be clustered, is most likely to require a single management option that serves all residences, including the possibility of wastewater use on a common land area.

Detailed lot size controls (including minimum lot sizes) will more appropriately be decided at the LEP/LES stage. However, the rural residential release strategy should identify areas that are broadly compatible with on-site sewage management (or able to be sewered), subject to working out appropriate minimum lot sizes and cost-effective ways of managing wastewater.

### 1.2.2 LOCAL ENVIRONMENTAL PLANS



LEPs have traditionally been the earliest stage in the planning process at which on-site sewage management has been considered. If a rural residential release strategy has not been prepared, the LEP should address the issues raised above.

If a rural residential release strategy has been prepared before a comprehensive LEP, the issue of on-site sewage management and land capability will have already been looked at on a broad scale. The LEP should therefore be concerned with refining the level of analysis, and in particular should:

- identify areas that should be eliminated from rezoning because they cannot sustain on-site sewage management or cannot be sewerred
- identify the appropriate density of development to ensure that development is sustainable and public health is protected
- assess the most suitable method of on-site sewage management.

Representative testing of different soil landscape types should occur as part of this process.

LEPs involving the rezoning of large areas of land from a rural to a residential zoning will often require a formal LES, which should address, among other things, the capacity of the land to sustain on-site sewage management.

If site-specific rezonings are proposed, it is important that the level of analysis that occurs in relation to on-site sewage management is similar to that required for subdivision. A subdivision layout should be provided, and the site should be evaluated and the soil tested as described in 'The Site and Soil Assessment' in Section 4. The appropriate minimum lot size should be established at this stage.

### 1.2.3 DEVELOPMENT CONTROL PLANS

The local council will often prepare a development control plan (DCP) to support a comprehensive rural residential LEP; it should contain additional details, such as:

- minimum land application areas
- setbacks to watercourses, boundaries, etc.
- recommended or required treatment technologies and on-site sewage management methods
- performance standards or criteria, for example in relation to effluent quality - suspended solids, biochemical oxygen demand (BOD), faecal coliforms, etc. - and quantity
- vegetation retention/planting/harvesting
- water conservation measures.

A DCP may be the best place to nominate prescriptive requirements such as minimum land application areas, which can be worked out during the environmental analysis done as part of the rural residential release strategy or LEP. A DCP provides the flexibility for local councils to refine requirements where the underlying performance objective of the requirement can be met in another way. An example may be where an applicant can show that the performance objective underlying a requirement such as a minimum land application area can be met using alternative technologies or an innovative lot layout with a lesser area of land.

#### 1.2.4 DEVELOPMENT APPLICATIONS - SUBDIVISION

In the past, the first time that on-site sewage management has been addressed has often been when land is being subdivided for residential development.

The subdivision stage is too late in the development process to consider on-site sewage management for the first time, as the land will usually already have been rezoned and development densities prescribed by the LEP. This can lead to the situation where inappropriate expectations are raised about minimum lot sizes that are not consistent with the environmental capability of the land and/or the operational requirements of the technology used.

If a detailed DCP does not exist, subdivision planning must include a detailed analysis of on-site sewage management requirements, and in particular:

- a detailed site and soil evaluation in accordance with the information on site and soil assessment in Section 4 of these guidelines should be done
- the capacity for innovative or centralised sewerage systems should be established, and
- appropriate on-site sewage management technologies should be investigated.

#### 1.2.5 DEVELOPMENT APPLICATIONS – DWELLINGS

The DA/BA that is submitted for an individual dwelling will show the proposed location of the house, the proposed on-site sewage treatment system and the land application area required.

Preferably, the details of on-site sewage management should be resolved at the DCP or subdivision stage so that the process of approving individual devices - if this is the preferred strategy - can be straightforward.

Section 4 of these guidelines indicates the appropriate level of site and soil assessment required.





## **Section Two**

# **On-site Sewage Management Strategies**

## 2.1 INTRODUCTION

Councils have primary responsibility for controlling on-site sewage management systems in their areas and are given a wide range of powers and functions for this purpose. These include general community leadership, land use planning, development control, regulation of activity, and the provision of on-site sewage management services. Preparing an on-site sewage management strategy (OSMS) is an effective way to set objectives and prioritise resources.

An OSMS provides a formal framework for integrated policy development and service planning, and it should include dynamic links to established processes for regional coordination, environmental assessment, statutory planning, service planning, program budgeting, revenue raising and community accountability. For example, information from the OSMS should be used in preparing the Council's Management Plan, its Annual Report, and its State of the Environment Report under the Local Government Act, as well as relevant development standards for subdivision, development and building control and council regulatory and service programs for on-site sewage management.

The on-site sewage management strategy should take into consideration related strategies for water supply, sewerage and stormwater management, as well as catchment management plans and the views of community stakeholders and of councils of neighbouring areas (especially those within the same water catchment). The views of relevant Government agencies (including the Department of Urban Affairs and Planning, the Environment Protection Authority, NSW Health, the Department of Land and Water Conservation and the Department of Local Government) should also be considered.

The "Environmental Guide for the Management of Local Government Water Supply, Sewerage and Drainage" published by the Department of Land and Water Conservation (DLWC 1997a) provides an overview of relevant environmental management tools and principles and is an essential resource for the preparation of a local council on-site sewage management strategy.

The final form and content of the OSMS is a matter for council decision.

The OSMS should include:

- a statement of the objectives for on-site sewage management in the council's area
- a statement of specific on-site sewage management goals
- a statement of programs and resources to achieve those goals
- a statement of the evaluation processes to be adopted in relation to those programs
- a commitment to continuing improvement of on-site sewage management in the council's area.

The OSMS should be supported by a full assessment of the nature and impact of existing on-site sewage management systems and of the environmental and social factors affecting system performance. See Appendix 1 for a sample checklist for a council OSMS.



## 2.2 DEVELOPING AN ON-SITE SEWAGE MANAGEMENT STRATEGY (OSMS)

### 2.2.1 POLICY, SCOPE AND PURPOSE

An introductory section should be provided, including:

- background information on the development of the OSMS
- the status of the strategy, when it was adopted and when it comes into effect
- the scope of the strategy, and
- the purpose of the strategy.

The statement of purpose might be:

- to provide a framework to manage and regulate the impact of on-site sewage management systems in the area, and to ensure community accountability
- to help the council prioritise resources for efficient regulation and monitoring of on-site sewage management in the area
- to coordinate environmental assessment, data collection and monitoring.

It is useful to explain how the OSMS relates to other management planning and statutory planning processes of the council. For example, the sections dealing with on-site sewage programs and funding will provide input to the Management Plan; the sections dealing with environmental assessment, system surveys and mapping will provide input to the State of the Environment Report; and the objectives and goals of the OSMS will provide input to the development of council policies for subdivision, development and building control and for the regulation of on-site sewage management systems.

A consistent and purposeful approach to on-site sewage management should be emphasised and a commitment made to continual improvement.

### 2.2.2 OBJECTIVES

The objectives of the council's OSMS should include:

- protection of groundwater
- protection of surface water
- protection of land and vegetation
- prevention of public health risk
- maintaining and improving community amenity
- ensuring maximum re-use of resources consistent with other objectives
- ecologically sustainable development.

Any other objectives that are relevant to local circumstances and consistent with the objectives specified in these guidelines should be included.

### 2.2.3 GOALS

The OSMS should specify particular goals for the council's on-site sewage management functions, both in the short and medium term. These will reflect the stage of development of particular functions and programs and will guide the development of new and improved on-site sewage management programs.

The statement of goals might be:

- to adopt a partnership approach with households and service agents to support continual improvement of on-site sewage management
- to build and maintain a database of all existing on-site sewage systems
- to determine the structures and facilities needed to support on-site sewage management systems
- to map and maintain details of soil and site conditions and suitability for on-site sewage management systems
- to provide a training program for operators of on-site sewage management systems
- to consult with householders on the development and implementation of a strategy to eliminate illegal discharges from pump-out systems
- to consult local plumbers and service agents and to specify qualifications for third party certification of maintenance work and compliance with approval standards
- to ensure that all land application areas comply with environment and health protection standards and council operating requirements
- to ensure that all septic tanks are inspected by qualified people at regular intervals and are desludged and maintained as required
- to consult Aerated Wastewater Treatment System service agents and to ensure that maintenance reports also certify that land application of effluent is being done in compliance with site requirements
- in cooperation with householders, to develop a site-specific sewage management plan for each household using an on-site sewage management system
- to review council development standards and approval criteria for subdivision, development and building to ensure that appropriate provision is made for sustainable on-site sewage management when residential development occurs in non-sewered areas.



## 2.2.4 PROGRAMS AND RESOURCES

The Programs and Resources section of the OSMS should specify the action to be taken to achieve specific goals and general objectives. It might help to distinguish between environmental assessment, monitoring programs, regulatory programs, service programs and educational programs. It is also appropriate to identify non-council inputs in this section.

The allocation of council resources to particular programs and the determination of council revenue policies are matters for the council's Management Plan. Clear links should be established between the Programs and Resources section of the WMS and the council's management planning process. Funding proposals for on-site sewage management programs should be raised in the OSMS and formally adopted in the Management Plan.

The consultation process is likely to be more efficient if specific strategies such as the OSMS are released for public exhibition with the Management Plan.

Councils are able to raise revenue for on-site sewage management programs and services mainly through:

- ordinary rates for general council administration and services
- special rates (including fixed-term capital rates) levied on particular parcels of land that have access to, benefit from or contribute to the need for particular programs and services
- charges for on-site sewage management services actually provided to particular properties
- approved fees for services (including regulatory services) to people
- developer charges (levied under s.64 of the Local Government Act and s.94 of the Environmental Planning and Assessment Act).

Council's on-site sewage management functions usually relate to specific premises or to a need arising because of activity occurring on specific premises. Some of the costs associated with new or improved on-site sewage management programs will be recovered from regulatory fees. Consideration should be given to levying special rates on premises using on-site sewage management systems, in order to fund environmental assessment, monitoring and reporting and community education programs. The appropriate revenue mix for on-site sewage management activities is a matter for each council to consider in the context of the OSMS and the council's Management Plan.

The development and determination of council planning policies and regulatory policies are matters that must be dealt with in accordance with relevant legislative frameworks. Existing policies concerning on-site sewage management issues should be listed as resources, and clear links should be established between goals and programs specified in the OSMS and the council planning and regulatory policy development processes.

All relevant legislation, regulations, planning instruments, development standards and local policies should be identified in the Programs and Resources section. Important provisions should be noted and copies of relevant documents should be made available. Council administrative arrangements, codes of practice and operating procedures should be identified.

Specific on-site sewage management plans can be prepared for particular localities as a means of coordinating different system management requirements in environmentally sensitive areas or of specifying technical limitations arising because of site conditions and available services. When such plans are prepared, they should be identified in the Programs and Resources section in a schedule that shows:

- which areas have on-site sewage management plans that are being implemented
- which areas have plans that are being developed
- which areas are nominated for future on-site sewage management plans.

A risk management plan that assesses pollution risks and sets out detailed action to be taken in specific circumstances should be included in the Programs and Resources section.



## 2.2.5 EVALUATION

The Evaluation section of the OSMS should include performance indicators for key goals and programs and arrangements for the ongoing evaluation of program effectiveness. Performance indicators should use existing data collections where possible and should be reported in measurable or quantifiable terms that are meaningful to councillors, staff and the community.

The initial implementation effort for new programs could be demanding, and progress targets should be referenced to reinforce the objective of continual improvement.

An example of the use of performance indicators is set out in Table 2 .

**Table 2: Example Performance Indicators for the OSMS**

Goals	Performance Indicator/Target
<ul style="list-style-type: none"> <li>to survey and maintain a database of all existing systems</li> </ul>	<ul style="list-style-type: none"> <li>number of surveys entered each year</li> <li>proportion of total entered each year</li> <li>complete surveys of 75% of existing systems within three years</li> </ul>
<ul style="list-style-type: none"> <li>to map and maintain details of soil and site conditions for on-site sewage management</li> </ul>	<ul style="list-style-type: none"> <li>all identified high risk areas in two years</li> <li>at least 90% of new residential subdivision and development applications in three years</li> <li>at least 75% of applications for new or upgraded on-site systems in three years</li> </ul>
<ul style="list-style-type: none"> <li>to provide a training program for households using on-site sewage management systems</li> </ul>	<ul style="list-style-type: none"> <li>develop a communications strategy including information, education and field workshop components to pilot stage in two years</li> <li>provide household information packs to all operators within one year</li> </ul>
<ul style="list-style-type: none"> <li>to ensure that land application areas comply with management requirements</li> </ul>	<ul style="list-style-type: none"> <li>specify requirements for land application areas in LOP/LAP in one year</li> <li>develop and implement effective inspection and enforcement strategies in two years</li> <li>95% of areas to comply in three years</li> </ul>
<ul style="list-style-type: none"> <li>to ensure all septic tanks are inspected by qualified people at regular intervals and are desludged and maintained as required for effective performance</li> </ul>	<ul style="list-style-type: none"> <li>develop and implement maintenance policies for all septic tanks in two years</li> <li>determine who is qualified to inspect and certify septic tanks in one year</li> <li>no fewer than 95% of all septic tanks to be desludged at least once every five years</li> </ul>

## 2.2.6 CONTINUING IMPROVEMENT

The OSMS should contain a commitment by the council to continuing improvement in the regulation and operation of on-site sewage management systems. There is no underestimating the size of the task that councils face to address poor on-site sewage management practices and to achieve the basic environment and health protection objectives of these guidelines. Consequently, the OSMS should be a dynamic and evolving process of continual improvement.

The results of the evaluation and monitoring programs adopted under the OSMS will show where deficiencies and strengths are, and where changes may need to be made. New technology will emerge that may prompt councils to re-evaluate the preferred systems. Ideally, council should review the OSMS each year as part of its management planning process, and should do a major review at least once every four years.

## 2.2.7 ATTACHMENTS

### **Appendices**

Although the OSMS is essentially a strategic management document, it might be appropriate to include or reference technical guidelines (for example, for site assessment, irrigation area calculations, system selection, operation and monitoring) as appendixes.

### **Glossary**

Include a glossary to explain any difficult or uncommon terminology.

### **References**

Include full references.





## **Section Three**

# **Operational Strategies**



## 3.1 REGULATING ON-SITE SEWAGE MANAGEMENT SYSTEMS

There are significant risks to public health and the environment associated with all forms of human waste management. These risks are generally well managed in the case of centralised sewerage systems, which are operated by competent authorities and are subject to performance and accountability requirements. The performance of on-site systems is more variable, because they are operated by individual householders and service agents, and because performance and accountability requirements are less clearly defined. There is evidence that existing on-site systems are failing to meet environment and health protection standards in many parts of NSW. The reasons suggested for system failures include initial planning and design faults, increasing wastewater loads, inadequate system maintenance and operator errors.

Amendments to local government regulations have clarified the responsibilities of householders and councils to ensure that on-site sewage management systems comply with performance standards and do not pose a risk to public health and the environment.

Effective council regulation of on-site sewage management systems requires a planned risk management approach, combining information gathering, community consultation and education, a flexible performance-based system of regulatory controls and efficient cost effective service programs. The local council should:

- develop, implement, and regularly review an on-site sewage management strategy
- consider all relevant issues when approving the installation or operation of on-site sewage management systems, particularly environment and health issues, both within the site and on a catchment-wide basis
- specify site- and system-specific conditions of approval to operate on-site sewage management systems
- check that approval conditions are complied with by appropriate monitoring or auditing
- undertake ongoing householder education on issues including:
  - the statutory responsibilities of householders as owners or operators of on-site sewage management systems
  - health and environment risks associated with system use
  - specific issues related to the system installed.

As part of a strategic approach to sewage management, local councils are encouraged to implement a program of system audits to monitor the performance of on-site systems and also to monitor the impact of on-site sewage management on the wider environment. The information obtained should be used for council service development and land use planning purposes and for State of the Environment Reporting.

Various State Government departments have a statutory or advisory role in relation to public health, sewage management, land use planning and environment protection. NSW Health assesses and accredits commercially distributed human waste treatment devices and can specify conditions that must be adopted to ensure safe operation. Regional Public Health Units can provide advice on health risk assessment and management. Government agencies, including the EPA, DUAP, DLWC and DLG can provide sewage management advice to local councils, householders and service or product providers.

## 3.2 LOCAL POLICY REQUIREMENTS FOR ON-SITE SYSTEMS

### General

The operating requirements for each sewage management system in the council's area should be clearly specified in local policies, conditions of approval and local sewage management plans. Details of the responsibilities of all relevant parties (including occupiers, landlords, tenants, service agents, third party inspectors, pump-out operators and biosolids contractors) should be included.

### Householders

Householder responsibilities should be specified for the safe operation of on-site sewage management systems in local approval and order policies and in published guidelines. Householders should have a sound understanding of the operating requirements of the treatment system they are using and should be aware of the need to adjust household activities accordingly (for example, by using low phosphorus detergents, minimising use of household chemicals, avoiding 'shock loading', and conserving water). Appendix 8 includes model pamphlets that may be copied and distributed to households.

Particular consideration should be given to the educational needs of new owners and tenants when a property with an on-site sewage management system is sold or leased. If such a property is to be used as holiday accommodation, the council should ensure that letting agents are aware of their environment and health protection responsibilities and that transient occupants observe water conservation and good on-site sewage management practices.

### Service Agents

The council may specify training and accreditation requirements for service agents as a condition of approval to install or operate an on-site sewage management system. If service agents are given an inspection and certification role, the council may also specify standard testing procedures, site management checks and reporting requirements, as well as procedures for lodging reports and for maintaining accreditation as a qualified person.

It is inadequate for service agents simply to report on the maintenance of treatment devices. Service agents should also be required to check land application areas and to confirm that site maintenance, buffer distances and access control requirements are being complied with.

Local policy requirements for inspection and service reporting could include standard inspection checklists, mandatory provisions in service contracts, and a standard methodology for sampling, testing and analysis of effluent. Inspection reports should cover the full system, including household fixtures, plumbing, septic tanks, pumps, blowers, sensors, alarm systems, effluent storage systems, land application areas, biosolids management and risk management procedures.

Councils are strongly encouraged to develop model on-site sewage management inspection reports and standard methodologies for sampling and analysis in consultation with system manufacturers, adjoining councils, and with regional public health and environment protection authorities.

### Support Facilities

Particular consideration should be given to the availability of support facilities for transporting and processing residuals (sludge and pump-out effluent) and to the impact of these related activities. Standards for plant and equipment for pump-out services should be specified and, where relevant, standards for sewage pre-treatment and ejection devices on sites with poor access to sewer connections should be specified.

## 3.3 ENVIRONMENTAL AUDITS, MONITORING AND REPORTING

The on-site sewage monitoring program should be based on the principles of risk management, accountability and total quality management. Water quality monitoring programs should be developed to assess and report on the impact of on-site sewage management systems. Particular attention should be paid to the format in which data are to be presented and how the information is to be used. The monitoring program could include:

- regular monitoring of the water environment in sensitive areas (sand dunes, alluvial flats, granite and basalt aquifers, wetlands)
- checking of performance to specifications of various on-site systems
- householder service checks
- long-term monitoring of effluent management.

Details of on-site sewage treatment devices that do not comply with accreditation requirements or that regularly fail should be reported to NSW Health.

Local councils should keep registers of on-site sewage management approvals, including relevant service reports and inspections. This information must be maintained in a format that is readily accessible to the public, and it must be made available on request.

Local councils are also required to produce State of the Environment (SoE) Reports, which must be updated each year. The impact of on-site sewage management systems and the measures proposed to manage identified risks to health and environment should be addressed in these reports.

## 3.4 EDUCATION AND TRAINING

An important part of on-site sewage planning and management is ensuring that all stakeholders are aware of their responsibilities and have access to enough appropriate information and other resources to carry them out. The level of knowledge needed will depend on the type of sewage management system and what the stakeholder needs to do.

The operation of centralised sewerage systems requires limited input from individual householders, but householders need to take an active role in the operation of on-site sewage management systems. They should have a broad knowledge of on-site sewage management principles and be able to apply that knowledge responsibly.

All stakeholders - including system manufacturers, regulators and service providers - should develop appropriate education and training programs to encourage best management practices for on-site sewage management systems.

### 3.4.1 TRAINING NEEDS

Some of the basic knowledge and skills involved in on-site sewage management are set out below in Table 3. This list is not exhaustive but it shows the range of topics stakeholders should be familiar with.

Householders using on-site sewage management systems are an important target audience for community education programs. Education and training programs for household operators should be based on modern adult learning principles and should recognise that adult learners bring many different factors to the learning process. These factors include differences in cultural and educational background, language difficulties, life experiences, preferred learning styles, attitudes, values and interests. Field days and problem solving workshops with a practical orientation are likely to be particularly beneficial to household operators.

Regulatory agencies that develop training programs should also recognise the need to emphasise the process (not just the content), use a variety of stimuli, use participant-generated resources, and use a mixture of plenary and small group workshops.

**Table 3: Basic Knowledge and Awareness Required by Stakeholders**

Stakeholder	Relevant Knowledge/Awareness
Householders	<ul style="list-style-type: none"> <li>• health risks and how to manage them</li> <li>• managing the environmental impact of wastewater</li> <li>• system selection and design of effluent application areas</li> <li>• system operation and maintenance</li> <li>• site, soil, climate and vegetation assessment results</li> <li>• waste minimisation principles and techniques</li> <li>• where to get further information if needed</li> </ul>
Developers and vendors	<ul style="list-style-type: none"> <li>• accreditation of domestic wastewater treatment devices</li> <li>• performance standards for on-site sewage management</li> <li>• soil, climate and vegetation factors in site assessment</li> <li>• assessment and design of effluent irrigation areas</li> <li>• on-site sewage management technologies</li> <li>• design principles for on-site sewage management</li> <li>• environmental responsibilities</li> <li>• regulatory requirements</li> <li>• operation and maintenance requirements</li> <li>• consumers' rights</li> <li>• occupational health and safety requirements</li> <li>• known environmental constraints of the local area</li> <li>• when to engage professional services</li> </ul>
Service providers	<ul style="list-style-type: none"> <li>• system design and treatment processes</li> <li>• operation and maintenance requirements</li> <li>• performance standards for environment and health protection</li> <li>• regulatory requirements and obligations</li> <li>• consumers' rights</li> <li>• occupational health and safety requirements</li> <li>• environment protection responsibilities</li> </ul>
Local council officers as representatives of regulatory agencies	<ul style="list-style-type: none"> <li>• regulatory and legislative framework and requirements</li> <li>• council strategies, policies and guidelines</li> <li>• health risk assessment procedures and management strategies</li> <li>• wastewater limits on ecologically sustainable development</li> <li>• water cycle management and the strategic assessment of community on-site sewage management options</li> <li>• soil and water conservation principles</li> <li>• coordinating stormwater and on-site sewage management</li> <li>• soil, climate and vegetation factors in site assessment</li> <li>• on-site sewage management technologies</li> <li>• using performance standards in the selection and design of systems for difficult sites</li> <li>• operation, maintenance and upgrading of existing systems</li> <li>• occupational health and safety requirements</li> <li>• environmental health principles and practice - managing risks</li> <li>• environmental assessment and planning</li> <li>• developing community education and participation programs</li> </ul>

### 3.4.2 TRAINING RESOURCES

New education and training resources for on-site sewage management are being developed by a number of institutions. Much more work is needed, and stakeholders are encouraged to share information and offer training opportunities to a broad range of participants.

Local councils are encouraged to develop community education strategies and to investigate other training opportunities available from:

- universities and TAFE colleges
- the Environment Protection Authority
- the Department of Land and Water Conservation
- other councils
- catchment management committees and trusts
- professional institutions and societies such as
  - the Australian Institute of Environmental Health
  - the Australian Society of Soil Science Inc.
  - the Australian Water and Wastewater Association
  - the Institution of Engineers Australia
- the Organic Waste Recycling Unit, NSW Agriculture
- the Building Services Corporation, Department of Fair Trading
- manufacturers' associations, such as the AWTS Manufacturers Association
- manufacturers and/or their agents for particular product systems.

Training opportunities can take the form of continuing education programs for interested members of the community and professionals, accredited courses for formal vocational training, public information releases, practical workshops, public notices and advertising, newsletters, regulatory updates, letterbox drops and community forums.

Sample brochures with general information about a range of on-site sewage management issues are included in Appendix 8 of these guidelines. Local councils may adapt them for use in local householder education programs.

## 3.5 RESPONSIBILITIES OF OTHER STAKEHOLDERS

The design, installation, operation and maintenance of on-site systems that comply with the performance objectives of these guidelines requires various stakeholders to carry out their responsibilities diligently. If threats to public health or the environment are identified, the responsible party should take urgent corrective action. This could include reporting to the local council, remedial action and the development of strategies to prevent further problems.

### 3.5.1 DEVELOPERS

Developers should ensure that the establishment of on-site systems is in accordance with all requirements of the regulatory authorities. It is important for developers (before installing the system if possible) to provide householders with the following information:

- the (likely) capital and ongoing costs of the system
- details of the regulating authorities conditions for the installation and the operation of the system
- the name of the system manufacturer
- system information provided by the manufacturer
- the name(s) of the service agent(s) acceptable to the local council.

Developers should ensure that qualified professionals do the site and soil assessments.

### 3.5.2 VENDORS, AGENTS AND SERVICE PROVIDERS

Manufacturers, vendors, agents and service providers have the responsibility to ensure that an on-site sewage management system is appropriate for, and is being used for, its intended purpose.

If a service provider observes that a system failure has been caused by improper use of the system, the service provider should consult with the owner. If the problem continues, then the matter should be reported to the local council for appropriate action. When effluent causes pollution of areas outside the property boundary, the service provider should report the situation to the local council.

All service providers must have appropriate training.

Manufacturers should have in place a product certification - quality assurance system or a quality assurance system as specified by AS/NZS/ISO 9002 or AS/NZS/ISO 9001 (Standards Australia 1994). Installation contractors should have a quality assurance system of the type specified in AS/NZS/ISO 9002 or other suitable and effective management controls.

Service providers should ensure that advice and education on system operation and maintenance are provided to customers and householders at every available opportunity. Vendors must make sure that the householder gets an operating manual and that additional copies are available on request. Vendors must also ensure that the local council has a full set of specifications, maintenance manuals and operating manuals for each type of system installed in the council's area.

The manual should cover:

- system operation and capabilities
- operating requirements - system capacity, the importance of spreading the hydraulic load, and actions to be avoided
- troubleshooting and signs of system failure - such as odours and surface ponding of wastewater
- maintenance and servicing requirements
- management of health risks
- occupational health and safety, first aid and chemical handling
- warranty and service life
- emergency telephone numbers.

Service agents should be able to do temporary repairs within 24 hours of being notified of a problem, and to correct any immediate risks to public health.

Service agents should produce a report, in triplicate, of each service call. This report should certify compliance with operating requirements and specify repairs undertaken and test results. The service agent should give the householder the original of this report. They should give a copy to the council, and keep an audit copy.

Service agents should ensure that any residual materials removed from an on-site sewage management system are handled and dealt with in accordance with environment and health protection standards and local council requirements.

### 3.5.3 HOUSEHOLDERS

Householders (owners and/or occupiers) are responsible for the correct operation of an on-site sewage management system on their premises. Correct operation involves regular supervision and system maintenance. Householders should be aware of system management requirements and should ensure that the necessary service contracts are in place.

Householders should be provided with information by service providers, developers, vendors and local councils to ensure they are aware of operation and maintenance requirements. Owners should ensure that other occupiers are also aware of operation and maintenance requirements.



If a system is defective and cannot be corrected by proper operation and maintenance, householders should report this to their local council and arrange for a system replacement. If a failure or departure in design is noted, the relevant service providers and NSW Health should be notified regarding the product accreditation.

#### 3.5.4 NEIGHBOURS

Neighbours who have problems with the operation of an on-site sewage management system on adjacent land are entitled to approach the local council for a remedy. Councils have a duty to regulate the operation of on-site sewage management systems so that risks to health and the environment do not arise. They should take all reasonable steps to ensure that effluent is wholly contained within an approved effluent application area at all times. Complaints about contamination of surface water or spray drift should be dealt with urgently. Complaints about odour problems should also be investigated, since this can be an early sign of mismanagement or system failure.





## **Section Four**

# **Evaluating The Site**

## 4.1 INTRODUCTION

Choosing the appropriate site for on-site sewage management can be the single most important factor in establishing an on-site sewage management system that is functional and environmentally sound in the long term. Site factors such as soils, climate and topography can place constraints on on-site sewage treatment technologies and land application systems. It is therefore essential that the site be evaluated to find out if it is suitable.

The aims of the site evaluation are:

- to broadly identify land suitable for development
- to collect site and soil assessment data to help identify and design an on-site sewage management system best suited to the site
- to work out the minimum desirable land areas per household.

At all stages of the evaluation process the performance objectives of these guidelines should be considered.

It is important that sewage management issues are addressed as early as possible in the planning and development process. At each step of the planning process different levels of assessment could be required. (See Table 1 in Section 1.) The level and extent of the evaluation will depend on a number of factors, such as:

- the stage of the planning process - rural residential release strategy, REP, LEP, DCP, DA, etc.
- data available from previous studies and plans (DCPs, LEPs, REPs) or EISs
- data and information available from soil landscape maps from DLWC, GIS, etc.
- the size and density of the proposed development and its potential for wastewater production (if known)
- the risk of adverse environmental impacts, the presence of environmentally sensitive areas, and the vulnerability of the groundwater
- past and present performance of local on-site sewage management systems.

Ideally the evaluation proceeds from a broad evaluation and desktop analysis to more detailed subdivision survey work. For individual lots that have not been covered by subdivision survey a single site evaluation would be required.

Suggested appropriate scales at which information should be gathered are as follows:



Rural residential release strategy	1:100,000 to 1:250,000 (DLWC Soil Landscape Maps are mapped at a scale of 1:100,000 to 1:250,000)
Subdivision	1:10,000 to 1:25,000
Individual site	1: 5000 to 1:1000

The evaluation steps are:

- **Broad evaluation (including desktop study).** This is best done as part of a rural residential release strategy (see Section 1) to avoid later duplication at the subdivision and individual site development stage. The desktop analysis is a review of all relevant information available and consideration of the major constraints and opportunities relating to the management of wastewater in relation to the proposed development. It includes considering all issues that have regional and local environmental significance for the area.

Aerial photos and other remote sensing data might need to be examined, areas of ground assessed, and soils assessed and sampled to verify the information provided in the desktop study or fill information gaps. This type of assessment could be done on a single catchment, multiple LGAs, a single LGA, or part of an LGA.

- **Site and soil assessment.** For subdivisions or individual sites. A detailed assessment of the site factors of expected available areas (such as slope, aspect, groundwater, soil permeability and soil chemistry) is done, and the site constraints are evaluated, so that the most suitable sewage management system can be chosen.

In general, the broad evaluation, including the desktop study, would be the responsibility of the relevant local council(s), particularly for the rural residential release strategy and LEPs. Generally, the site and soil assessment steps would be the responsibility of the developer or landholders. Councils should, however, stipulate the requirements of all steps.

DLWC can assist councils and others doing desktop studies and site and soil assessments.

The site and soil characteristics that should be considered are included in these guidelines to help councils, developers and individuals understand why they are critical in the site evaluation process.

**Site and soil evaluation should be done by suitably qualified soil scientists who are experienced in assessing all the parameters discussed in this section.** The Australian Society of Soil Science Inc. maintains a list of accredited professional soil scientists who specialise in land evaluation and soil survey. DLWC can also help councils to find qualified and experienced people to do this type of work.

To ensure that all appropriate site factors are assessed and evaluated, the local council could produce a standardised site report. Appendix 2 is an example of such a report. Councils might also consider using Tables 4 to 8 as checklists.

## 4.2 THE BROAD EVALUATION - DESKTOP STUDY

Sewage management considerations should be included in the development of rural residential release strategies, REPs and LEPS. Land, soil and climatic information should be assessed to determine the broad constraints and compatibilities for on-site sewage management over a selected area. One or more local councils would normally do the evaluation over an area of one or more LGAs and report the results as part of a rural residential release strategy.

The aim of the study is to make a preliminary classification of the land into those areas with few, moderate or major limitations to on-site sewage management, and to do a preliminary assessment of the preferred systems to be used. Identifying the constraints as early as possible in the planning process should improve the efficiency of the next steps of the site evaluation, because land with major limitations will be excluded from further study.

The desktop evaluation should include:

- an assessment of the existing infrastructure
- an assessment of future council plans for the area, including provision of infrastructure
- an assessment of the performance of any existing on-site systems. Classify areas in which existing on-site systems do not generally match site and soil constraints, where systems are failing, or where systems are or are likely to be causing health and environmental impacts
- a preliminary assessment of the practicality of providing centralised sewerage systems where reticulated water exists or can be supplied, or where there are major limitations to on-site management
- an overview of the soil and landscape (topography, geology, groundwater, vegetation, rock outcrops) features across the area, taking into account the degree and location of constraints that could affect the siting, design, sizing, installation and maintenance of on-site systems
- a description of the extent and nature of any environmentally sensitive areas and the potential for impacts upon these
- monthly 50th percentile precipitation data and monthly evaporation data and its expected variation over the study area
- calculation of a water balance and storage requirements over the area using the rainfall and evaporation data (see Appendix 6)

- collection of information on groundwater vulnerability, the nature of any aquifers, the location of bores, watertable heights, and the nature and extent of any groundwater quality and use
- mapping of flood risk contours and setbacks from waterways or other sensitive areas
- an assessment of potential impacts and cumulative impacts over time of establishing on-site sewage management systems in the area under investigation, paying particular attention to surface and groundwater contamination and salinity hazard
- preliminary classification of the expected available areas, if any. Areas identified as having major limitations do not generally need to be assessed further, as development will not be occurring in these areas unless another form of sewage management is used (such as some form of centralised sewerage system)
- preliminary identification of suitable on-site sewage management systems, if any
- preliminary identification of minimum lot sizes and maximum development densities.

It should be noted that land application systems operating mainly by soil absorption, with only limited evapotranspiration, are in some instances sewage disposal, not use, systems. The potential for nitrate contamination of groundwater, in particular, is increased with the use of these systems if nitrogen has not been removed from the effluent. It is important that local councils assess and determine the environmentally sustainable density of on-site sewage systems for any given area.

For example, an investigation of groundwater contamination by septic tank effluent in Victoria (Hoxley & Dudding 1994) showed that towns or cities with septic tank and trench systems in densities of about 15 systems per square kilometre are most likely causing nitrate and bacterial contamination of the local groundwater systems. This is similar to a US Environment Protection Authority recommendation that more than 15 septic tank and trench systems per square kilometre have the potential to contaminate groundwaters (USEPA 1992). Also, the West Australian Water Authority has set a limit of 25 septic tank and trench systems per square kilometre where there are significant potable water supplies from groundwater (Rawlinson 1994).

The information gathered at the desktop study phase might need to be clarified further. For example, if there is no scale information available on, say, groundwater or soils, field investigation could be needed at this stage. Sometimes information will have been mapped or gathered at a scale that is too small to provide enough detail for the area under consideration. If this is the case, the information will have to be verified by site visits and investigations.

Soil and site information can be obtained from the Soil Data System, soil landscape maps and groundwater vulnerability maps (available from the DLWC), various geographic information systems, aerial photos, reports, studies and local knowledge. These sources may help identify site parameters and limitations, such as steep slopes, flood hazards,

wetlands and other environmentally sensitive areas, and erosion hazards such as mass movement.

Information is also available from the Bureau of Meteorology (climatic data), the EPA and NPWS (environmentally sensitive areas), and local State of the Environment Reports.

At this stage of evaluation, local councils should assess the potential cumulative impacts of establishing on-site systems in an area, particularly the potential increase in nutrient concentrations or salinity within the study area catchment. This is crucial in areas where on-site sewage management systems are already in use and further systems are proposed.

The level of detail of the investigation will depend on the stage of the planning process. For example, a more detailed picture of the area under consideration and its relationship with its surroundings should be included at the LEP stage; the information may take the form of a local environmental study (LES) or other environmental investigation.

The broad evaluation and desktop assessment might show that on-site sewage management is not appropriate in certain areas, and that development should not proceed unless more suitable management options can be provided (such as partial on-site or total off-site management).

## 4.3 THE SITE AND SOIL ASSESSMENT

The site and soil assessment is generally the responsibility of the developer or landholder, who should put together the information gathered in the desktop study and the site and soil assessment to gain a detailed understanding of the area under consideration. Local councils should stipulate the requirements for the assessment.

DLWC can assist councils on all aspects of site and soil assessments for single sites and subdivisions.

### 4.3.1 ASSESSING FOR SUBDIVISIONS

The site and soil assessment should be done at the subdivision planning stage or when preparing a site-specific LEP. If a number of lots are planned, a site and soil survey is more efficient, thorough, and cost effective than assessments for individual sites. Potentially available areas will have already been identified in the desktop study, along with those areas with only moderate limitations. Moderate limitations can sometimes be overcome by appropriate selection, design, and sizing of on-site systems, or by modifying the site.



If there are map scale discrepancies, areas assessed as available in the desktop phase might have to be reclassified according to the findings of the more detailed assessments.

All potentially available areas identified in the desktop study should be traversed on foot, and the boundaries of these areas should be delineated more accurately if necessary. The site and soil assessment should be done before the final delineation of individual lots, although a further soil assessment might be needed for the development of individual lots.

The site assessment should be done in conjunction with the soil assessment. Potential locations for on-site sewage management systems should be identified based on the features listed in Table 4. Areas where sites are limiting or unsuitable for the installation of on-site systems should be avoided.

For proposed subdivisions, a sufficient number of soil profiles should be assessed to allow characterisation of an area. Soil assessment should be comprehensive so as to allow determination of appropriate sewage management options.

The following (briefly outlined) soil assessment process is recommended.

1. The desktop study will have identified the potentially available areas, based on existing soil maps or (where there is no or limited soil information) on topography, geology and land use history. The location of sites should be predetermined using air photo interpretation in conjunction with details from the desk top study.
2. Divide the site into areas containing relatively homogenous soil types, or patterns of soil types. These areas are generally best delineated according to the soil parent material (surface lithology) and landform elements (see glossary for definition.) Make at least three soil descriptions from pits or cores dug in each of the areas. The pits or cores should be positioned across the area to detect as much soil variation as possible. Use at least three additional auger holes or other soil observations to confirm patterns of soil variation within each area. Keep notebook records of all soil observations. Show numbered locations of all soil description and observation sites on the final map. The map should also show contours, drainage lines and existing infrastructure.
3. Excavate soil pits and cores to 1.2 metres or the restrictive horizon (for example, the hardpan or standing watertable), whichever is the shallower. If soil absorption systems are the preferred choice of system, and information about depth to groundwater at the site is not available from the desktop study, then investigate to 1 m deeper than the proposed system base depth.

Make profile description pits large enough for the soil profile to be viewed and identified to 1.2 metres. Samples should be taken for each major soil horizon and analysed for the parameters set out in Table 6 unless otherwise specified in Table 7. Information

from soil cores or pits and laboratory data should be described using the NSW Soil Data System (details available from DLWC.)

Observe occupational health and safety regulations and take all necessary safety precautions for work in pits.

4. If the observations and pits show that there are no major limitations to on-site sewage management, and there is no wide variability in system design within the area, then individual lots may not need to be evaluated further.
5. If any of the cores or pits show major limitations to on-site management, then there are two options:
  - potential application areas will need to be assessed individually, or
  - landform/soil areas are further divided or modified and the assessment repeated until the three observations and three pits/cores all demonstrate few limitations.

An alternative to on-site management may be recommended if major limitations are found.

#### 4.3.2 ASSESSING FOR SINGLE LOTS

To make sure the lot sizes are adequate and meet the requirements for on-site sewage management, it is recommended that a site and soil assessment is done before the land is subdivided into single lots. If the assessment has not been done at the subdivision stage and individual lots have already been delineated, a separate site assessment should be done for each individual property. The site and soil assessment should be aimed at identifying the most appropriate application area(s) within the lot and the most appropriate on-site sewage system to be used.

The site assessment should be done in conjunction with the soil assessment. Potential locations for on-site sewage management systems should be identified based on the features listed in Table 4. Areas where sites are limiting or unsuitable for the installation of on-site systems should be avoided.

Assess three soil profiles (pits or cores) to a depth of 1.2 metres for each proposed land application area. If soil absorption systems are the preferred choice of system, and information about depth to groundwater at the site is not available from the other studies, then investigate to 1 m deeper than the proposed system base depth. Also, the number of soil profiles needed will depend on soil variability and site sensitivity. Suggested locations of the soil profiles are:

- one pit/core at the centre of the proposed land application area
- one adjacent to the proposed treated wastewater entry point
- one at the opposite end of the land application area from where the treated wastewater is entering.

Samples should be taken for each major soil horizon and analysed for the parameters set out in Table 6 unless otherwise specified in Table 7. Information from soil cores or pits and laboratory data should be described using the NSW Soil Data System (details available from DLWC.)

All relevant soil features should show only minor limitations to on-site sewage management for all pits and cores.

### 4.3.3 SITE FEATURES

Descriptions of the site features that should be assessed are listed on the next page. For more information on these features, including assessment details, see the *Australian Soil and Land Survey Field Handbook* (McDonald et al 1990).

Note that not all features apply to all system technologies. Table 4 lists systems relevant to each site feature, along with recommended limiting parameters. It is important to assess all relevant features. Local councils might consider using Table 4 as a checklist.

Descriptions of the site features that should be assessed are listed below. For more information on these

**The most limiting feature determines the site capability for a land application system or on-site sewage management system.** In some cases the problems posed by a limiting feature or features can be overcome by using special designs or by modifying the site.

**Table 4: Site Assessment: Rating for On-site Systems**

Site Feature	Relevant System(s)	Minor Limitation	Moderate Limitation	Major Limitation	Restrictive Feature
Flood potential	All land application systems	Rare, above 1 in 20 year flood contour		Frequent, below 1 in 20 year flood contour	Transport of wastewater off-site
	All treatment systems	Vents, openings, and electrical components above 1 in 100 year flood contour		Vents, openings, and electrical components below 1 in 100 year flood contour	Transport of wastewater off-site. System failure and electrocution hazard
Exposure	All land application systems	High sun and wind exposure		Low sun and wind exposure	Poor evapotranspiration
Slope%	Surface irrigation	0-6	6-12	>12	Run-off, erosion
	Sub-surface irrigation	0-10	10-20	>20	Run-off, erosion
	Absorption system	0-10	10-20	>20	Run-off, erosion
Landform	All systems	Hill crests, convex side slopes and plains	Concave side slopes and footslopes	Drainage plains and incised channels	Groundwater pollution hazard Resurfacing hazard
Run-on and upslope seepage	All land application systems	None - low	Moderate	High - diversion not practical	Transport of wastewater off-site.
Erosion potential	All land application systems	No signs of erosion potential present		Signs of erosion, eg rills, mass movement and slope failure, present	Soil degradation and transport, system failure
Site drainage	All land application systems	No visible signs of surface dampness		Visible signs of surface dampness, such as moisture-tolerant vegetation (sedges and ferns), and seepages, soaks and springs	Groundwater pollution hazard Resurfacing hazard
Fill	All systems	No fill	Fill present		Subsidence. Variable permeability
Buffer distance	All land application systems	(see Table 5)			Health and pollution risks
Land area	All systems	Area is available		Area is not available	Health and pollution risks
Rocks and rock outcrops (% of land surface containing rocks >200mm diameter)	All land application systems	<10%	10-20%	>20%	Limits system performance
Geology / Regolith	All land application systems			Major geological discontinuities, fractured or highly porous regolith	Groundwater pollution hazard

(compiled from various sources)

## Climate

Climate influences the use of the hydraulic load of the wastewater for all types of land application systems. Areas with high evaporation compared with precipitation are preferred for land application systems, as they allow greater use of the hydraulic load. Areas using irrigation and experiencing periods when rainfall exceeds evaporation **must store treated wastewater during periods of wet weather**. Applying wastewater during wet weather could make pollutants leach to groundwater, or the wastewater could surface, with consequent environmental and health risks.

A water balance based on historical precipitation and evaporation data for the locality should be completed and used to help design irrigation systems. The water balance concept is explained in Section 5, and Appendix 6 contains a sample calculation.

Average maximum daytime temperatures below about 15°C decrease the performance of wastewater treatment processes that rely on biological activity (such as AWTS and composting toilets). Some technologies use external heating components to overcome these difficulties.

## Flood Potential

It is best to locate all the components of on-site systems above the 1 in 100 year probability flood contour, but the 1 in 20 year probability contour may be used as a limit for land application areas.

Electrical components, vents and inspection openings of wastewater treatment devices should be sited above the 1 in 100 year probability flood contour.

## Exposure

Sun and wind exposure on land application areas should be maximised to enhance evaporation. Factors affecting exposure include the geographical aspect of the area, and vegetation and buildings near the proposed application area. Evaporation may be reduced by up to two-thirds in some locations by a poor aspect or overshadowing and sheltering by topography, buildings or vegetation.

## Slope

Excessive slope might pose problems for installing systems and create difficulties in evenly distributing the treated wastewater to land, resulting in run-off from surface land application areas. The recommended maximum slope will vary depending on the type of land application system used and the site and soil characteristics. The values given in Table 4 are based on ideal site and soil conditions. If these conditions are less than ideal the maximum slope requirement should be reduced.

## Run-on and Upslope Seepage

Run-on of precipitation on to the land application area from up-gradient areas should be avoided. Run-on should be diverted around any land application area by using earthworks

or a drainage system approved by the local council.

Upslope seepage can be at least partly controlled by installing groundwater cut-off trenches, provided the lowest level of the trench is above the level at which effluent can enter the land application area.

### Erosion Potential

On-site systems should not be put on land that shows evidence of erosion, or that has potential for mass movement or slope failure.

### Site Drainage

On-site systems should not be installed on damp sites. Poor drainage and surface dampness are often indicated by the type of vegetation growing on the site. Sedges and ferns are likely to grow in damp conditions. Seepage, springs and soaks are also indications of poor site drainage.

Site drainage can best be determined by inspecting the soil.

### Fill

Fill can be described as soil resulting from human activities that have led to modification, truncation or burial of the original soil or the creation of new soil parent material by a variety of mechanisms. Fill often has highly variable properties, such as permeability. Fill can be prone to subsidence, and could contain material that might not be suitable for plant growth or for constructing land application systems. Fill can be removed, but if this is not possible a detailed assessment of the fill might be needed. Fill less than 0.3 metres deep could be suitable, depending on the nature of the material and the suitability of the underlying soil.

### Buffer Distances

Buffer zones should be kept between on-site systems and sensitive environments on and off-site, to ensure protection of community health, the environment and community amenity.

A buffer distance should be left between on-site sewage management systems (particularly land application areas) and features like boundaries of premises, driveways, buildings and swimming pools.

When determining buffer distances, consideration should be given to:

- the type of land application system to be used
- surface and subsurface drainage pathways
- site factors - soil permeability, geology, vegetation buffering
- sensitive environments - national parks, rainforests, estuaries, wetlands, groundwater extraction areas, and areas with poor tidal flushing
- development density.

Recommended buffer distances for various systems are shown in Table 5. The values given are a recommended minimum, based on ideal site and soil conditions. If these conditions are less than ideal, the minimum buffer distances should be increased.

There should be a horizontal distance of 250 metres between a land application area and a groundwater well used for domestic water supply.

Where land application areas are planned within drinking water catchments and other sensitive areas, advice on adequate buffer distances should be sought from the relevant water authority and a hydrogeologist (DLWC).

**Table 5: Recommended Buffer Distances for On-site Systems**

System	Recommended Buffer Distances
All land application systems	<ul style="list-style-type: none"> <li>• 100 metres to permanent surface waters (eg river, streams, lakes etc)</li> <li>• 250 metres to domestic groundwater well</li> <li>• 40 metres to other waters (eg farm dams, intermittent waterways and drainage channels, etc)</li> </ul>
Surface spray irrigation	<ul style="list-style-type: none"> <li>• 6 metres if area up-gradient and 3 metres if area down-gradient of driveways and property boundaries</li> <li>• 15 metres to dwellings</li> <li>• 3 metres to paths and walkways</li> <li>• 6 metres to swimming pools</li> </ul>
Surface drip and trickle irrigation	<ul style="list-style-type: none"> <li>• 6 metres if area up-gradient and 3 metres if area down-gradient of swimming pools, property boundaries, driveways and buildings</li> </ul>
Subsurface irrigation	<ul style="list-style-type: none"> <li>• 6 metres if area up-gradient and 3 metres if area down-gradient of swimming pools, property boundaries, driveways and buildings</li> </ul>
Absorption system	<ul style="list-style-type: none"> <li>• 12 metres if area up-gradient and 6 metres if area down-gradient of property boundary</li> <li>• 6 metres if area up-gradient and 3 metres if area down-gradient of swimming pools, driveways and buildings</li> </ul>

### Land Area

Sufficient and appropriate land must be available within the boundary of the premises for the following uses (where appropriate):

- sewage management system, including treatment system, dedicated land application areas and reserve areas
- buffer distances
- house and associated structures
- social and recreational uses
- vehicular access areas.

### Rocks and Rock Outcrops

The presence of rock outcrops usually indicates highly variable bedrock depths, and can be associated with preferential pathways (short-circuits) for effluent to flow along rock fissures and surface elsewhere.

The presence of rocks can limit evaporation and interfere with drainage. Rocks can also interfere with trench and pipe installations. Cobbles and larger stones can collapse into installations, causing problems with even effluent distribution.

### Geology/Regolith

Land application areas should not be installed near major geological discontinuities or fractured or highly porous regolith, as these structures can provide short-circuits of wastewater to groundwater.

#### 4.3.4 SOIL FEATURES

Soil is a complex arrangement of mineral and organic particles that vary horizontally and vertically in space, and vary with time. Having an understanding of the soil on a site will be a great help in choosing and sizing an on-site sewage management system that will perform to the expectations set out in the performance objectives of these guidelines.

While the broad evaluation / desktop study will provide preliminary information on soil characteristics, a soil assessment is needed for accurate assessment. Local councils should stipulate requirements for the soil assessment in the OSMS and/or an LEP or DCP.

Soil assessments involve observing and measuring attributes within a soil profile. A soil profile is a vertical section of soil consisting of various soil horizons. A soil horizon is a layer of soil that may differ from adjacent layers in physical, chemical and/or biological properties. In general, soil characteristics can be assessed from auger borings, soil pits, soil cores or existing vertical exposures, like roadside cuttings.

The soil features that should be assessed are listed below. For more information on these features (including assessment and analysis requirements) see the following texts:

- *Australian Soil and Land Survey Field Handbook* (soil data card handbook) (McDonald et al 1990)
- *Australian Laboratory Handbook of Soil and Water Chemical Methods* (Rayment, G E & Higginson, F R 1992).

Local councils might wish to use Table 6 as a guide. Note that not all features apply to all technologies. Table 6 lists systems relevant to each soil feature, along with recommended limiting parameters. It is important to assess all relevant features.

**The most limiting feature determines the site capability for a land application system or on-site sewage management.** In some cases the problems posed by a limiting feature or features can be overcome by using special designs or by modifying the site.



**Table 6: Soil Assessment: Rating for On-site Systems**

Soil Feature	Relevant System(s)	Minor Limitation	Moderate Limitation	Major Limitation <sup>1</sup>	Restrictive Feature
Depth to bedrock or hardpan (m)	Surface irrigation Sub-surface irrigation	>1.0	0.5 - 1.0	<0.5	Restricts plant growth (trees), excessive runoff, waterlogging
	Absorption system	>1.5	1.0 - 1.5	<1.0	Groundwater pollution hazard Resurfacing hazard
Depth to high episodic/seasonal watertable (m)	Surface irrigation Sub-surface irrigation	>1.0	0.5 - 1.0	<0.5	Groundwater pollution hazard Resurfacing hazard
	Absorption system	>1.5	1.0 - 1.5 <sup>2</sup>	<1.0	Potential for groundwater pollution
Soil permeability Category <sup>3</sup>	Surface irrigation Sub-surface irrigation	2b, 3 and 4	2a, 5	1 and 6	Excessive run-off, waterlogging, percolation
	Absorption system <sup>4</sup>	3 and 4		1,2,5, and 6	
Course fragments(%)	All land application systems	0-20	20-40	>40	May restrict plant growth, affect trench installation
Bulk density (g/cm <sup>3</sup> )	All land application systems				Restricts plant growth, indicator of permeability
Sandy Loam		<1.8		>1.8	
Loam & clay loam		<1.6		>1.6	
Clay		<1.4		>1.4	
pH <sub>CaCl</sub>	All land application systems	>6.0	4.5 - 6.0	-	Reduces optimum plant growth
Electrical conductivity (ds/m)	All land application systems	<4	4-8	>8	Excessive salt may restrict plant growth
Sodicity (exchangeable sodium percentage) <sup>5</sup>	Surface irrigation Sub-surface irrigation (0-40cm)	0-5	5-10	>10	Potential for structural degradation
	Absorption system (0-1.2m)				
Cation exchange capacity (cmol <sup>+</sup> /kg) (0-40cm)	Surface irrigation Sub-surface irrigation	>15	5-15 <sup>6</sup>	<5	Unable to hold plant nutrients
Phosphorus sorption (kg/ha) (0-100cm for irrigation) (100cm below intended base of trench)	All land application systems	>6000	2000-6000	<2000	Unable to immobilise any excess P
Modified Emerson Aggregate Test (dispersiveness)	All land application systems	Class 1	Class 2	Class 3,4	Potential for structural degradation

(compiled from various sources)

**Notes:**

1. Sites with these properties are generally **not** suitable.
2. Presence of soil water might indicate soil conditions that favour movement of nutrients and other contaminants into the groundwater.
3. See Table 8.
4. Rate of application should not exceed 2 - 5 mm/day for soil absorption systems.
5. Because of the elevated levels of sodium in domestic wastewater, gypsum should be put on application areas each year. Soil absorption systems should also be dosed on a regular basis.
6. Soil is likely to become more sodic with effluent irrigation.

Table 7 indicates the level of soil assessment recommended for subdivisions and single sites. The reduced level of assessment for single sites only applies to those sites where a detailed survey has been carried out at the subdivision stage or where the site is isolated and the on-site sewage management system poses minimal threat to the environment.

**Table 7: Soil Tests Required for Different Situations**

Soil Test, Method and Reference	Subdivision	Single Site
Bulk density (core or clay method)	Yes	No
Soil pH (1:5 soil:water)	Yes	Yes
Electrical conductivity(1:5 soil:water) Conversion to EC <sub>e</sub> necessary	Yes	Yes
Cation exchange capacity and exchangeable cations, exchangeable sodium percentage	Yes	No
Phosphorus sorption	Yes	If suspected problem
Modified Emerson aggregate test (SAR 5)	Yes	Yes, field test
Particle size analysis (hydrometer)	Yes	No
Linear shrinkage	Yes	If suspected problem
Saturated hydraulic conductivity	If marginal, in dispute or doubtful	No

Note: Yes is for all major soil horizons from fully described major soil profiles

### Depth of Soil

A soil depth of less than 0.6 metres to bedrock might not have enough capacity to filter nutrients and pathogens. Shallow soil often has a highly variable depth, and incurs a risk of effluent surfacing near the land application area.

The recommended minimum soil depth will vary depending on the type of land application system used and the site and soil characteristics. The values given in Table 6 are based on ideal site and soil conditions. If these conditions are less than ideal the minimum soil depth requirement should be increased.

### Depth to Episodic/Seasonal Watertable

Attention should be given to groundwater protection, particularly if the groundwater is used or may be used for potable or irrigation water supplies. In such areas, consider baseline and ongoing groundwater monitoring to allow both the detection of deteriorating groundwater quality and protection of aquifers.

Once a particular contaminant has reached the groundwater, the rate of transport will be much greater than in the unsaturated zone, and movement will be in the direction of the regional groundwater movement. Microorganisms can be carried substantial distances in this zone (Hoxley & Dudding 1994).

Minimum depths from the treated wastewater infiltrative surface to the minimum periodic watertable and/or gravel layer in a floodplain adjoining a river or stream are recommended to maintain aerobic conditions in the soil, prevent surface ponding and prevent contamination of groundwater. These minimum depths will vary, depending on the type of application system proposed and the site and soil characteristics of the site. The values given in Table 6 are a recommended minimum, based on ideal site and soil conditions. If these conditions are less than ideal, the minimum depth to the watertable should be increased.

For more information about groundwater contact the DLWC. Only preliminary assessment might be needed for single lot development, but for subdivision planning further investigation could be required.

The depth to the episodic/seasonal watertable level can be assessed through observation and assessment of characteristics such as soil colour, mottling and segregation of pedogenic origin (see below).

Mottles are spots, streaks, speckles or blotches different from the matrix colour. Soil colour can be assessed using the Munsell colour chart system. Bright, uniform soil colours typify well drained, well aerated soils. Dull, grey, mottled soils indicate continuous or seasonal saturation. A bleached A2 horizon can indicate poor drainage and a perched watertable.

Segregations of pedogenic origin are nodules or concretions that have formed within the soil profile from chemical or biological action and that differ in composition from the majority of the soil material. They are described in terms of abundance, nature, form and size and can be observed by eye or by simple chemical reactions.

Iron, iron-manganese, aluminium or manganese nodules within a soil profile generally indicate alternate wetting and drying with waterlogging.

### Soil Permeability

Saturated hydraulic conductivity (permeability) is a measure of the ability of a soil to transmit water, and is quoted as the value for the least permeable layer of a soil profile. It is affected by soil properties like structure, texture and porosity.

In general, highly permeable soils such as gravels and sands can allow wastewater to percolate rapidly through the soil profile, possibly allowing the transport of pathogens and nutrients to groundwater and off-site. Low permeability soils, such as medium and heavy clays, can encourage waterlogging and surfacing of the applied wastewater.

Permeability can be estimated by a field assessment of soil texture and structure, where the properties of a soil are correlated with a certain indicative permeability (see Table 8). **Permeability assessment should be done by a soil scientist.**

Soil texture refers to the field behaviour characteristics of a soil when it is manipulated. It relates to the relative proportions of clay (<0.002 mm diameter particles), silt (0.002 - 0.05 mm diameter particles) and sand (0.05 - 2.0mm diameter particles) in the soil as well as its chemical characteristics.

Soil structure refers to the aggregation of soil particles into clusters of particles, called peds, that are separated by surfaces of weakness (openings, or voids). This can greatly modify the influence of soil texture on water movement. Well-structured soils with large voids between peds will transmit water more rapidly than structureless soils of the same texture. Fine-textured, massive soils have very slow percolation rates.

Structure is determined by observing a pit exposure and is described in terms of grade and type of pedality, and size of peds.

**Table 8: Soil Permeability Categories Based on Soil Texture and Structure**

Soil Permeability Category	Soil Structure	Soil Texture
1		Gravels and sands
2a	Weakly pedal	Sandy Loams
2b	Massive	
3a	Highly/moderate pedal	Loams
3b	Weakly pedal or massive	
4a	Highly/moderate pedal	Clay loams
4b	Weakly pedal	
4c	Massive	
5a	Highly pedal	Light clays
5b	Moderately pedal	
5c	Massive	
6a	Highly pedal	Medium to heavy clays
6b	Moderately pedal	
6c	Massive	

If there is some doubt about the soil structure, texture, or the likely permeability category, then the hydraulic conductivity can be estimated by other methods. Methods include but are not limited to the use of double ring infiltrometers, disc permeameters, or Geulph, Talsma, and Hallam permeameters. A liquid of similar composition to effluent (SAR 5) should be used. Measurements should be done by appropriately experienced and qualified persons. The clean water percolation test should not be used to determine soil permeability.

### Coarse Fragments

Coarse fragments are those particles larger than 2 mm in diameter. Coarse fragments can pose limitations on root growth, and lower the soil's capacity to supply water and nutrients to the vegetation. More than 40% coarse fragments would be limiting to land application systems. Coarse fragments can also interfere with trench installations.

### Bulk Density

Bulk density is the mass of dry soil per unit bulk volume. It is a measure of soil porosity and structure. Specific soil textures have a critical bulk density. The following bulk densities for the specified soil textures should not pose problems for land application areas:

sandy loam:	<1.8 g/cm <sup>3</sup> (grams per cubic centimetre)
loam and clay loam:	<1.6 g/cm <sup>3</sup>
clay:	<1.4 g/cm <sup>3</sup>

### pH

The pH value of a soil influences soil conditions and vegetation growth. Soil pH affects the solubility and fixation of some nutrients in soils. Soils with a pH of between 4.5 and 8.5 should pose no constraints for land application areas.

### Electrical Conductivity

High electrical conductivity (EC), corresponding to high concentrations of soluble salts in a soil, is undesirable for vegetation growth. Salt concentration in soil is indicated by the EC of an extract from a 1:5 soil:water paste. To convert EC 1:5 deciSiemens per metre (dS/m) to EC<sub>e</sub>, a multiplier factor related to the soil texture is required (see Hazelton & Murphy 1992).

The tolerance of vegetation species to soil salinity varies among vegetation types. An EC<sub>e</sub> of greater than 4 dS/m is suggested as a limit above which vegetation growth problems can occur.

### Sodicity

The level of exchangeable sodium cations in a soil is referred to as sodicity. It relates to likely dispersion on wetting and shrink/swell properties. Sodic soils tend to have low infiltration capability, low hydraulic conductivity, and a high susceptibility to erosion. Exchangeable sodium percentage (ESP) is used as a measure of sodicity.

### Cation Exchange Capacity

Solid particles in soil often carry a negative surface charge. The overall neutrality of the system is maintained by the presence of cations close to the solid surface. These cations may be exchanged with others. This process is referred to as adsorption, a reversible surface phenomenon that does not involve a chemical reaction. Adsorbed cations may be retained by the soil, or used by vegetation.

The cation exchange capacity is the total number of cations a soil can retain on its adsorbent complex at a given pH, and is therefore a good measure of a soil's ability to retain specific pollutants. The most abundant cations in soil are calcium, magnesium, potassium and sodium, and hydrogen and aluminium in acid soils.

A cation exchange capacity of greater than 15 cmol<sup>+</sup>/kg is recommended for land application systems.

### Phosphorus Sorption Capacity

The capacity of a soil to adsorb phosphorus is expressed as its phosphorus sorption capacity. A medium to high sorption capacity is greater than the equivalent of 6000 kg/ha (considered to be active to 100 cm below effluent application level) and is preferred for land application areas. Phosphorus sorption by the soil is expected to occur up to about a quarter to half of the phosphorus sorption capacity. Beyond this, leaching of phosphorus can occur if the phosphorus is not used by vegetation uptake. A soil with a phosphorus sorption ability of at least 50 years (in terms of µg P/g soil), based on the expected phosphorus load, is recommended for land application areas.

A simple test to distinguish soils on the basis of low and high phosphorus retention is described in Rayment and Higginson (1992).

### Dispersiveness

Dispersive soils pose limitations to on-site sewage management because of the potential loss of soil structure when effluent is applied. Soil pores can become smaller or completely blocked, causing a decrease soil permeability, which can lead to system failure.

The modified Emerson Aggregate Test is a simple field assessment of aggregate dispersiveness based on a two-hour testing period. Three undisturbed samples of soil aggregate, and three reworked aggregates (from the textured bolus), about 5 mm in diameter, are each carefully immersed in a beaker of sodium adsorption ratio (SAR) 5 solution and left undisturbed for two hours.

The behaviour of the natural aggregate or worked bolus can be used as a guide to assess whether a soil is prone to dispersion.

## 4.4 THE SITE REPORT

Council might specify particular information that is required and the format of a site report through its OSMS, an LEP, or a DCP. When the developer or landholder has gathered all the soil and site information and decided on a system (see Section 6), he or she can give the council the site report containing all the information council needs to assess the application. Appendix 2 is a model site report which local councils can use as a basis.





## **Section Five**

# **On-site Sewage Management System Options**



## 5.1 INTRODUCTION

Domestic wastewater can be managed in a number of ways, and although these guidelines focus on the on-site management of wastewater it is important that local councils and developers are aware of all options when selecting and designing sewage management systems.

This section considers sewage management based on the following classification:

- total on-site management (including single or split systems of treatment)
- partial on-site management
- total off-site management.

### 5.1.1 MINIMISING WASTEWATER GENERATION

If wastewater is to be managed effectively, it is essential that wastewater generation is minimised for two major reasons:

- to conserve water as a precious natural resource
- to ensure that the wastewater does not overload the installed management system, which can then cause a public health risk, cause environmental damage or reduce public amenity.

Various water-saving devices have been used to conserve water, including dual-flush cisterns, water-conserving showerheads and water-conservative dishwashers and washing machines. Some water using appliances, such as spa baths, can be inconsistent with on-site sewage management. Water can also be conserved using a range of practices such as shorter showers, turning the tap off when cleaning teeth, ensuring that taps do not continuously drip, and using dishwashers and clothes washers only when the load is full. Some local councils have developed successful water conservation programs by promoting these practices.

### 5.1.2 CHARACTERISTICS OF UNTREATED DOMESTIC WASTEWATER

Domestic wastewater is derived from four main waste streams:

- kitchen
- bathroom (basin, bath and shower)
- laundry
- toilet.



Wastewater can be:

- blackwater - human excreta and water grossly contaminated with human excreta (such as toilet wastewater) (although not strictly water-based, human excreta entering waterless composting toilets is considered as 'blackwater')
- greywater (sullage) - wastewater that is still contaminated but not grossly contaminated with human excreta (such as kitchen, bath, shower and laundry wastes)
- a combination of blackwater and greywater.

Wastewater quality, quantity and flow-rate depends on the:

- availability of a reticulated water supply
- number of people in the household
- water conservation practices adopted by the household
- waste management practices used
- degree of water consumption by the installed appliances and fixtures.

Blackwater contributes, on average, 15 - 35% of the total domestic wastewater flow, depending on the capacity of the toilet flushing cistern tank. The remaining portion, the greywater, comprises about 65 - 85% of the flow.

Household wastewater flows in Australia are usually in the range of 150 - 300 litres per person per day (L/p/d) in areas provided with a reticulated water supply and 100 - 140 L/p/d in areas without a reticulated water supply.

Where on-site systems are proposed, particular attention must be given to the water-consuming appliances installed. The use of low flow devices (including dual six or three litre flush toilets) is recommended. Food waste disposal units and spa baths should not be connected unless on-site systems are designed for the additional load.

Table 9 presents typical pollutant concentrations in domestic wastewater, and the contributions of greywater and blackwater to these pollutant loads. Note that domestic wastewater, particular the greywater component, is highly variable. Table 9 also highlights the high pollutant loading of greywater and the difference in hydraulic load between households with and without access to a reticulated water supply. The local council might specify the wastewater characteristics for its area based on previous experience. These figures are compiled from a variety of sources and might be useful as a guide.

The following components are present in untreated and treated wastewater, although in differing concentrations.

## Water

Water is a major component of wastewater, and is present in combination with various dissolved, colloidal and solid constituents. Water, in terms of hydraulic load, is a key consideration in designing and operating on-site systems. Many on-site sewage management systems are also unable to cope well with large volumes of water such as several showers or loads of washing over a short period of time. These 'shock loads' should be allowed for in the selection and design of an on-site system.

## Organic Matter

Organic matter consists of chemical compounds based on carbon skeletons (proteins, carbohydrates and fats). Organic matter can be present in dissolved, suspended and colloidal form. With respect to domestic wastewater, it is usually measured in terms of the biochemical oxygen demand (BOD) of the liquid.

## Suspended Solids (SS)

Suspended solids (SS) in wastewater analysis are the solids retained after filtration through a glass fibre filter paper, followed by washing of the filter paper and drying of the residue at 105°C, or by centrifuging followed by washing and removal of the supernatant liquid. This includes both volatile and fixed solids. Volatile solids are driven off as volatile gases when heated to 600°C. Fixed solids are those remaining.

## Nutrients

Nutrients are chemical elements that are essential for sustained plant and animal growth. The most important nutrients with respect to domestic wastewater are nitrogen and phosphorus. These nutrients may be present in various forms in domestic wastewater.

## Pathogens

Pathogens are micro-organisms that can cause diseases. Pathogens include bacteria, protozoa and viruses. Pathogenic organisms are present in high numbers in untreated domestic wastewater. Wastewater treatment, including disinfection, decreases the number of pathogenic organisms present. Faecal coliforms are used as an indicator of pathogenic contamination.

### pH

pH is an indicator of the acidity or alkalinity of the liquid part of the wastewater.

### Sodium

The sodium level present in treated wastewater and soil is usually expressed as the sodium adsorption ratio, which relates the amount of sodium ions to the amounts of calcium and magnesium ions.



**Table 9: Characteristics of Typical Untreated Domestic Wastewater**

Parameter	Loading	Greywater %	Blackwater %
flow - non reticulated water supply	100 - 140 L/p/d	65	35
flow - reticulated water supply	150 - 300 L/p/d	65	35
Biochemical oxygen demand	200 - 300 mg/L	35	65
Suspended solids	200 - 300 mg/L	40	60
Total Nitrogen	20 - 100 mg/L	20 - 40	60 - 80
Total Phosphorus	10 - 25 mg/L	50 - 70	30 - 50
Faecal coliforms	10 <sup>3</sup> - 10 <sup>10</sup> cfu/100 mL	medium - high	high

### 5.1.3 THE THREE PHASES OF SEWAGE MANAGEMENT

Section 68 (1) of the *Local Government Act 1993* states that a person may install, construct or alter a **human waste treatment device (HWTB)** or **human waste storage facility (HWSF)** or a **drain** connected to any such device or facility only with the approval of the local council.

Using the terminology of the Local Government Act, the whole on-site sewage management system is comprised of three phases using:

- drains, although drains may be absent for waterless composting toilets (phase 1)
- HWTB and/or HWSF (phase 2)
- drains, representing the method of use or disposal (phase 3).

## Phase 1: Waste Capture and Conveyance

- Drains —→ Capture the wastewater from the fittings (toilet, bidet, hand-basin, shower, bath, kitchen and laundry) and convey the wastewater to a HWTD or HWSF.
- or
- Capture human excreta directly into a HWTD without the use of a drain.

## Phase 2: Waste Treatment or Storage

- HWTD —→ Treat the wastewater for storage, polishing, disposal or use.
- HWSF —→ Capture and store the human excreta in a cesspit for an extended period or store in a pan for frequent removal and management.

## Phase 3: Waste Use or Disposal

- Drains —→ Convey the treated wastewater from some of the HWTDs and use or dispose of the treated waste. These drains include ancillary systems such as constructed wetlands, amended soil systems, and mounds, as well as the method of land application such as soil absorption systems and irrigation systems.

Table 10 shows the relationship of the various commonly used types of HWTD and HWSF to the waste received, and the connection of drains.

**Table 10: On-site Sewage Management Systems**

Waste	Phase 1	Phase 2	Phase 3	Human Waste Treatment Device or Storage Facility
Blackwater and greywater	Drain	HWTD	Drain	<ul style="list-style-type: none"> <li>• Septic tank/collection well</li> <li>• Aerated wastewater treatment system</li> <li>• Wet composting toilet</li> <li>• Wastewater ejection unit</li> <li>• Common effluent system pretreatment device</li> <li>• Recirculating sand filter device</li> </ul>
Blackwater		HWTD	Drain	<ul style="list-style-type: none"> <li>• Septic closet</li> <li>• Waterless composting toilet</li> </ul>
Blackwater		HWTD		<ul style="list-style-type: none"> <li>• Chemical toilet</li> <li>• Combustion toilet</li> </ul>
Greywater excluding kitchen	Drain	HWTD	Drain	<ul style="list-style-type: none"> <li>• Greywater treatment device</li> </ul>
Blackwater		HWTD		<ul style="list-style-type: none"> <li>• Pan</li> <li>• Cesspit</li> </ul>

All phases of the management system provide some form of treatment of the wastewater. The first phase provides treatment by reducing the size of solids and mixing with water. The second phase (involving HWTD) may provide primary, secondary or tertiary treatment. The third phase may provide treatment using the soil, or by using ancillary systems such as amended soil systems, sand filters, and constructed wetlands to further improve the water quality before it is applied to land.

## 5.2 TOTAL ON-SITE SEWAGE MANAGEMENT

Total on-site management of domestic wastewater involves the treatment and use of all the wastewater generated completely within the boundary of the premises.

All wastewater and human excreta generated must be considered when selecting an on-site system. This is to prevent design and installation of a management system for only part of the wastewater stream (for example, installing a composting toilet and neglecting the remainder of the wastewater stream - kitchen, bath, shower and laundry - and the need for its sanitary management).

On-site sewage management systems are complex and can fail if not sited, designed, installed, operated and maintained correctly. All on-site sewage management systems require a proven design and a high degree of user dedication in terms of system operation and maintenance, to ensure that the design performance is achieved over the expected life of the system. Devices adopted for use should have a quality design and quality assured manufacturing process, and must be certified by NSW Health.

All on-site systems, or components of systems, have a finite life and will at some time require replacement. For example, septic tanks can have an expected life of 25 years, and soil absorption systems can have an expected life of 5 to 15 years. This should be acknowledged by all stakeholders and explained to householders by manufacturers and local councils.

## 5.3 ON-SITE SEWAGE MANAGEMENT FACILITIES

### 5.3.1 GENERAL CONSIDERATIONS

Wastewater, no matter where it comes from, can transmit disease and cause major environmental damage. Therefore, it should not be applied to land without treatment. This section gives a broad overview of on-site sewage treatment system installation, operation, and maintenance requirements.

## Installation

A service agent should install the system, and a licensed plumber/drainer should install all sanitary pipes and fittings. They should be authorised as required in Section 47 of the *Local Government (Water, Sewerage and Drainage) Regulation*. The Building Services Corporation of the Department of Fair Trading will be able to verify the validity of licences and offer guidance on consumer protection. The system should be installed as approved by the local council, using only human waste treatment devices certified by NSW Health. The installation should ensure structural integrity. All biological treatment devices require desludging, removal of by-products or harvesting of vegetation. There should be ample access for these and other activities such as servicing and maintenance. Ventilation should be adequate.

Local councils have primary responsibility to see that the installation complies with the approval. Local councils should implement the best management practice for the system. They should:

- encourage stakeholders to keep proper records for compliance audits
- empower the staff to carry out audits and inspections
- facilitate the education of the community in proper care of sewage management systems. This includes education and training programs for specific groups, and making available up-to-date operation and maintenance information for owners and occupiers. (see Section 3 for more information on education and training.)

## Operation

Householders have primary responsibility to minimise health, environmental and local amenity risks by ensuring that their on-site sewage management system is installed, managed, operated, serviced and maintained properly. This is because the system is installed on their premises, and they have the greatest exposure to possible risks.

### Householders should:

- practise water conservation, and avoid exceeding the system wastewater capacity. Spread heavy water use activities (such as from washing machines and dishwashers) over the whole week rather than concentrating it at weekends
- learn the location and layout of the treatment and land application systems
- avoid or minimise putting cleaning agents, detergents, disinfectants, bleaches, alkalis, oil, paint, petrol, acids, degreasers, photography chemicals, cosmetics, lotions, pesticides and herbicides into the system. These chemicals, even in small amounts, can upset the proper functioning of the system
- not place materials such as disposable nappies, sanitary napkins, tampons, paper towels, plastics, cigarette butts, bones and coffee grounds into the system. These materials can overload the capacity of the system to treat the waste, or make the pumps fail
- maintain the correct system operation at all times
- watch for signs of unsatisfactory system performance, including unusual odours, leaks and overflows from the system, choking of pipes, excessive noise and high power consumption

- 🔊 contact the service agent if the system is not performing properly or if it breaks down
- 🔊 protect the system components from structural damage by vehicles, lawn mowers and edgers
- 🔊 be familiar with safety procedures
- 🔊 set regular intervals for desludging or compost removal
- 🔊 keep the area near the system tidy to make the system easier to operate and maintain
- 🔊 enter into an annual service contract with a service agent authorised by the local council upon commissioning of the unit
- 🔊 keep copies of all service reports
- 🔊 not use treated wastewater for domestic purposes, for topping up the swimming pool or on edible crops.

## Maintenance

When service agents visit, they should assess the operation of the system, including any electrical and mechanical equipment, and the structural integrity of system.

Local councils should ensure that householders have maintenance contracts, and should remind them of their maintenance obligations. Local councils should keep a register of maintenance completed and required. They should also keep a register of appropriately qualified service agents, and could even consider offering this service. Service agents should be suitably qualified to maintain a range of systems.

Local councils should clarify their policies on on-site sewage management systems by developing on-site sewage management strategies, as well as local approval, monitoring, and surveillance plans. They should consider requiring periodic analysis of treated wastewater to check for compliance with the expected treated wastewater quality for the particular system. For example, if a sample is tested and it complies with the expected quality, then only annual testing might be needed. If the sample fails, then the system should be serviced and repaired where necessary, and another sample should be taken and tested within six months. If the sample again fails, then the system should again be serviced and another sample tested within 3 months. Continuous failure might indicate that the system needs to be upgraded. Where failure of a system poses a direct threat to the environment or public health, immediate remedial action will be required.

Local councils need to make sure there is a suitable depot available to receive septage. Septage (discussed under 'Septic tanks') must be managed appropriately in order to meet the performance objectives of these guidelines. Septage is usually removed by a service agent and transported to a centralised wastewater management facility or other approved facility for management.

### 5.3.2 SEPTIC TANKS - SEPTIC CLOSETS - COLLECTION WELLS

Septic tanks have been used since the 1920s and became more popular after the Second World War, when the current single chamber version was designed. They were initially



designed as a treatment process for rural residences where there was ample room for both installation and field disposal, and to replace the use of the cesspit for human excreta and rubble pits for sullage (greywater).

Septic tanks were also used extensively as a stop-gap measure in urban areas before the installation of centralised sewerage systems. Unfortunately, in many areas centralised systems were not provided and many soil absorption systems were not well maintained. This led to severe drainage problems and a major risk to public health when the effluent drained into creeks, stormwater channels and bathing areas. Accumulated environmental damage has been widespread in some areas because of the large number of defective septic systems.

### Treatment Process

A septic tank is a waterproof tank usually located below ground level. Septic tanks provide preliminary treatment for the entire wastewater stream by allowing solids to settle to the base of the tank, and oils and fats to float to the top to form a scum layer. Anaerobic (in the absence of oxygen) bacterial digestion of the stored solids produces sludge, which accumulates in the bottom of the tank. Partly treated odorous effluent flows from the septic tank to either further on-site treatment, a common effluent system, a holding tank for pump out, or directly to a soil absorption system.

**Figure 2: Cross-Section of a Septic Tank**

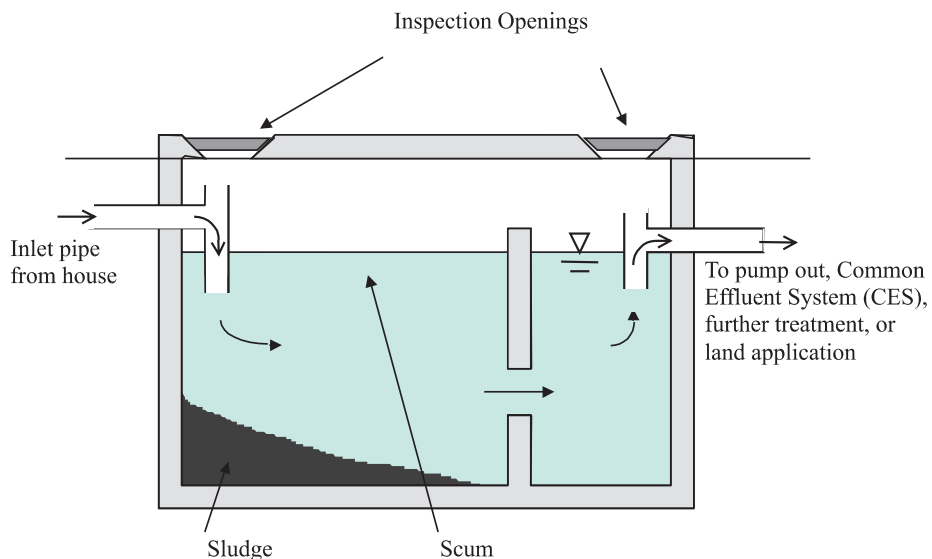

Septic tanks do not remove nutrients. The wastewater is not disinfected, and because it is highly infectious it must be applied to land below ground level. Typical water quality levels after partial treatment in a septic tank are listed in Table 11.

**Table 11: Expected Quality of Wastewater after Treatment in a Septic Tank**

Parameter	Concentration
Biochemical oxygen demand (BOD)	150 mg/L
Suspended Solids (SS)	50 mg/L
Total Nitrogen (N)	50 – 60 mg/L
Total Phosphorus (P)	10 – 15 mg/L
Faecal coliforms	10 <sup>5</sup> – 10 <sup>7</sup> cfu/100 mL

As the settled and digested solids undergo slight compaction and anaerobic decomposition, they need to be removed periodically to prevent odours, clogging of the tank, and carryover of solids with the treated wastewater - these can clog and shorten the life of the soil absorption system. Desludging should be done every three years, but the frequency depends on how heavily the system is used and the design of the tank.

The scum layer on the surface of the water should be fully formed, but not excessive, to ensure that the fermentation process remains anaerobic and to help stop odours escaping.

The tank must provide 24-hour retention time for the design wastewater flow; NSW Health provides sizing and design calculation criteria for both domestic and commercial installations. The domestic criteria are presented in Table 12.

### NSW Health Certification

The design criteria for domestic septic tanks and collection wells are specified in AS 1546 - 1990 *Small Septic Tanks*. The standard is currently under review. All septic tanks and collection wells (except for polypropylene septic tanks and collection wells until the standard is revised) must be licensed with Standards Australia, and must bear the AS Standards Mark, before they can be certified by NSW Health.

Before leaving the manufacturers' premises, all precast septic tanks and collection wells must be permanently and legibly marked with the following information:

- the day, month and year of manufacture (for example, 15/06/96)
- the manufacturer's name or registered trade mark
- the capacity of the unit in litres.

### Local Council Approval

Local councils may conditionally approve of septic tank and septic closet installations. A list of conditions commonly used by councils is attached as Appendix 3. The appropriate conditions from this list should be selected and applied, plus any others that are needed.

## Installation

Induct vents are no longer required on septic tanks, because they were easily damaged and allowed flies and mosquitoes to get in. An educt vent is still required on the house plumbing system.

Similarly, **grease traps** are no longer required, as they were found to be too small to trap grease effectively. Instead, the size of the septic tank was increased and a baffle installed to remove the need for a grease trap.

To ensure the structural integrity of the building and the septic tank installation, the tank and collection well must not be installed within 1.5 m of a building. Adequate **access** must be provided for maintenance, desludging and ventilation. Structures, including decking, must not be erected over septic tanks unless there is a means of access to the septic tank and collection well.

A collection well may be installed after a septic tank so that effluent can be collected and pumped to a land application area (or to the sewer or off-site) if the degree of fall prevents direct gravitation to a land application area. On particularly difficult sites, split systems, in which the septic tank accepts waste directly from the toilet and kitchen, may also be installed. The remainder of the wastes are drained to another land application area through a sullage tank or through a greywater treatment device. This shortens the life of the separate land application area, because solids might not be adequately removed. For this reason it is not recommended unless purpose-designed.

A **septic closet** is simply a water closet and hand-basin mounted directly on top of a septic tank. No other household wastes are discharged into the septic closet. Septic closets usually require the construction of a stand-alone structure or 'outhouse', and greywater needs to be managed in a separate system.

A **dual flushing cistern** with a nominal 3/6 litre flush, fitted with an external overflow connected to a WC pan with a nominal 50 millimetre water seal, should be fitted to every new installation. A nominal 9 litre flushing cistern fitted with an external overflow connected to a WC pan with a nominal 50 millimetre water seal may also be installed. The external overflow is to ensure detection of faulty cisterns and stop excess water from entering the septic tank. Most cisterns can be modified by plumbers. Manually operated cisterns must be installed in all septic tank installations.

**Soil line distance limitations** must be considered, as reduced flushing can limit the distances solids may be carried in the pipes. For an installation treating WC wastes only, or WC/basin wastes, the vertical drop in the soil line from the outlet of the pan must not be greater than 2.25 metres. For an installation treating WC wastes only, the horizontal length of pipe between the outlet of the pan and the inlet to the septic tank must be not less than 1.5 metres and not more than three metres. For an installation treating WC/basin wastes the horizontal length of pipe between the outlet of the pan and the inlet to the septic tank must not exceed five metres. The horizontal length of pipe between the outlet of the pan and the junction with another waste to the main drain line must not exceed three metres. This is to make sure that solids are carried to the septic tank or main drainage line, preventing drain blockages.

**Table 12: Criteria used for Calculating the Capacity of Domestic Septic Tanks**

(Note: N = number of people (minimum = 5); L = litres; BA = basic allowance for sludge accumulation)

Number of wastes	Septic Tank Capacity (Litres Minimum)	Collection Well Size (Litres Minimum)		
		Single Pump	Dual Pump	Weekly Removal
WC only	2050	2050	2050	2050
WC and basin	2050	2050	2050	2050
WC and all other wastes	1550(BA) (+150 x N) 2300 minimum	150 x N x 2 2050 minimum	2050	150 x N x 7 2050 minimum
<b>Note:</b> Installation of a food waste disposal unit or spa bath is not recommended				

The minimum capacity of a septic tank receiving all household wastewater is 2300 litres and must be fitted with an internal baffle. The minimum number of people for calculation of domestic septic tank capacities is five and the maximum number of persons for calculations is ten. (See Table 12.)

### Operation

Owners and occupiers should be aware of the operating recommendations mentioned earlier in this section. Enzyme additives have been promoted for reducing odour and preventing blockages in septic tank systems. However, there is a possibility that emulsified fats may be transferred to the land application system and cause problems. Properly designed and operated systems should not persistently rely on the use of enzyme additives.

### Maintenance

Service agents and councils should be aware of the maintenance recommendations mentioned earlier in this section.

Annual servicing should include assessment of the sludge and scum levels, and checking of the outlet and inlet square junctions for blockages.

Septic tanks should be desludged as required, and generally at a minimum every three years. Desludging is required when:

- the scum layer is within 100 mm of the bottom of the inlet square junction, or the sludge layer is within 200 mm of the bottom of the outlet square junction
- the sludge occupies the basic allowance (1550 L) of the septic tank, or
- the total depth of sludge and scum is equal to one-third of the depth of the tank.

The desludging procedure should ensure that 400 - 500 mm of liquid is retained in the tank, and that the tank is immediately refilled with water to the outlet level to prevent the tank from being lifted by soil hydrostatic pressure.

Septage consists of the sludge, scum and liquid pumped out from septic tanks during desludging. It has high pollutant levels, as shown in Table 13, and can contain organic contaminants from household products, and heavy metals leached from plumbing and copper fittings. Septage may be transported by truck to a centralised management facility or other facility approved by the local council. Under the *Local Government Act*, local councils should not permit the discharge of septage into a sewerage system without the prior approval of DLWC.

**Table 13: Characteristics of Domestic Septage**

Parameter	Typical Range (mg/L)
Total Solids	10 000 – 50 000
Suspended Solids	4 000 – 40 000
Biochemical oxygen demand	2 000 – 15 000
pH	6 - 9
Total Nitrogen	400 – 1 500
Total Phosphorus	50 – 500
Grease	3 500 – 9 500

### Advantages

- no operator required
- no moving parts
- low maintenance effort
- low energy requirement

### Disadvantages

- effluent is highly infectious and highly polluting
- subsoil (below ground surface) application is required
- soil absorption systems require relatively large land areas and must be properly assessed and designed
- home occupiers have a poor history of understanding the operation and maintenance of the system
- soil absorption systems often break down because the effluent is of poor quality, so they frequently need replacing
- many soils are not suitable for effluent absorption
- groundwater and surface water can become polluted or contaminated
- water conservation is essential.

### 5.3.3 AERATED WASTEWATER TREATMENT SYSTEMS (AWTS)

Aerated Wastewater Treatment Systems (AWTS) use aeration of wastewater as an integral part of the treatment process. These guidelines consider AWTS designed to treat all wastewater for households of up to ten people.

#### Treatment Process

AWTS treatment typically involves the following processes:

- settling of solids and flotation of scum in an anaerobic primary chamber (septic tank)
- oxidation and consumption of organic matter through aerobic biological processes
- clarification - secondary settling of solids
- disinfection using chlorination, or other approved means if surface land application of treated wastewater is to occur, and
- regular removal of sludge to maintain the process.

As with septic tanks, sufficient detention time is required for efficient operation of the system. The aeration phase might make use of either the suspended growth or attached growth (fixed film) process.

In **suspended growth systems** (activated sludge-type systems), microorganisms responsible for organic matter breakdown are suspended in the wastewater by mixing, and oxygen is provided mechanically. Air is supplied - either continuously or intermittently - by a small compressor and distributed to the aeration compartment by the use of diffusers, a fan, or other mixing device. Intermittent systems alternate between set periods of aeration and quiescence. Figure 3 shows the basic components and processes of a suspended growth AWTS.

**Attached growth systems** are also used for single household AWTS. In attached growth systems, microorganisms become attached to an inert medium such as rock or plastic, and the oxygen is provided naturally or by aeration. Attached growth systems include trickling filters or rotating biological contactors. Media used must have a large surface area to flow ratio and a self-cleaning action. A biological film (zoogloal film), consisting of bacteria and algae, develops and grows on the medium. The film eventually detaches from the medium and the resulting sludge accumulates in the aeration and settling compartments.

In most cases some sludge is returned automatically for aeration and the residual sludge is wasted to anaerobic digestion. This sludge must be managed in accordance with the requirements for septic tank septage.

Figure 3: Cross-Section of a Suspended Growth AWTS

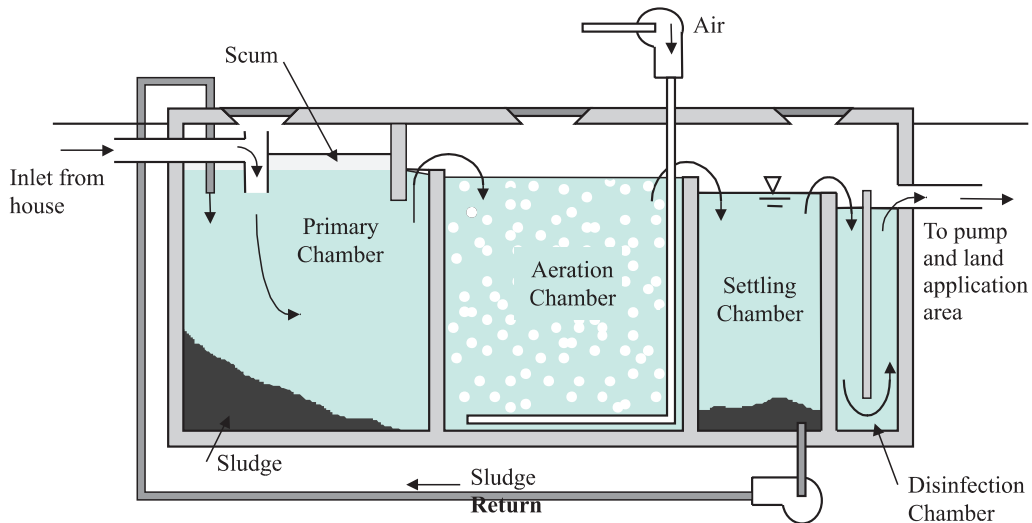

AWTS rely on biological activity for proper system operation. Sudden changes to the hydraulic loading into a system (either a rapid increase or sudden decrease in load) can result in poor system performance. A period of a few weeks is typically required during commissioning of the system to achieve the expected treated wastewater quality. **AWTS must be operated continuously; power to the system must not be turned off.** If AWTS are used at irregular intervals (such as for holiday homes) the system might need to be serviced at each start-up.

AWTS typically produce effluent of a higher quality than that produced by septic tanks, with lower BOD, lower suspended solid levels, and much lower faecal coliform levels. However, AWTS do not significantly reduce nutrient levels.

Table 14 specifies the expected effluent quality when a grab sample of the effluent is taken off the overflow from the disinfection chamber. It would be appropriate to use the specified values when conducting a monitoring survey in a local council area to assess compliance. AWTS must be well maintained and operated to achieve this quality on a continuous basis.

**Table 14: Expected Quality of Wastewater after Treatment in an AWTS**

Parameter	Concentration *	Failure Indicator
Biochemical oxygen demand	<20 mg/L	>50 mg/L
Suspended solids	<30 mg/L	>50 mg/L
Total nitrogen	25 - 50 mg/L	not applicable
Total phosphorus	10 - 15 mg/L	not applicable
Faecal coliforms Non-disinfected effluent	up to 10 <sup>4</sup> cfu/100 mL	not applicable
Faecal coliforms Disinfected effluent	<30 cfu/100 mL	>100 cfu/100 mL
Dissolved oxygen	>2 mg/L	<2 mg/L

\*Design figures might not be indicative of long-term operational characteristics

### NSW Health Certification

All AWTS must be tested by the manufacturers using an independent organisation for conformity to NSW Health protocols contained in the AWTS Approval Guidelines 1997. Testing must be completed using screened raw sewage from a municipal sewage treatment plant.

Companies marketing these systems will also have to set up a quality assurance system for consumer confidence. Manufacturers must supply full and detailed specifications for the AWTS to local councils in the areas in which they intend to market the systems. This makes it easier for local councils to do detailed inspections of the AWTS for conformity to certification immediately after installation.

The AWTS must be contained in a vessel (usually a septic tank or collection well) certified by NSW Health.

### Local Council Approval

Local councils may approve of AWTS installations conditionally. A list of conditions commonly used by local councils is attached as Appendix 4. The appropriate conditions should be selected and applied, together with any other conditions the local council might want to apply.



## Installation

An AWTS must be installed with an alarm that has visual and audible components to indicate mechanical and electrical equipment malfunctions. The alarm should have one signal next to it and one in a suitable position attached to the house. The alarm should incorporate a warning lamp, which may be reset only by the service agent.

Before the AWTS is commissioned, the local council must do a detailed inspection of the installation and the land application area.

## Operation

See 'On-site Sewage Management Facilities - General Considerations' earlier in this section. Also, make sure that power to the system is not turned off, even if the house is not in use. If the power is turned off, the system might have to be serviced at each start-up. After prolonged shut-off (more than 1-2 days), recommissioning will normally take 2-4 weeks to establish a stable treatment process. This is an important consideration if the house is occupied only sporadically (for example, a holiday home).

Biological activity is particularly sensitive to cleaning products, especially products that contain disinfectants such as bleaches. AWTS are also sensitive to pesticides, weedicides and pharmaceuticals such as antibiotics. Waste materials containing these products should not be discharged to an AWTS.

## Maintenance

AWTS are small sewage treatment plants and as such require regular servicing and maintenance. Centralised wastewater management facilities are usually maintained on a daily basis. However, to suggest that daily maintenance requirements be applied to an AWTS would be unrealistic and uneconomic. Accordingly, as a result of field trials, it was realised that these systems needed to be adequately serviced and maintained at 3-monthly intervals.

Therefore:

- the owner must be required to enter into an annual service contract with a service agent authorised by the local council
- the service agent must be able to provide service within 24 hours of being notified of a system malfunction
- the service agent should offer an annual service contract of four services at 3-monthly intervals. Each 3-monthly service should include a check on all mechanical, electrical and functioning parts of the AWTS including:
  - the chlorinator (where installed)
  - replenishment of the disinfectant
  - all pumps
  - the air blower, fan, or air venturi
  - the alarm system

- the effluent irrigation area, including the irrigation spray outlets
- the slime growth on the filter media
- the operation of the sludge return system
- free residual chlorine, using the DPD (N,-N-diethyl-p-phenylenediamine) colorimetric or photometric method
- pH from a sample taken from the irrigation chamber
- dissolved oxygen from a sample taken from the final aeration or stilling chamber (optional but recommended)
- the annual service should include a check on sludge accumulation in the septic tank (primary treatment chamber) and the clarifier where appropriate
- for systems that use the sewage treatment principle of activated sludge or contact aeration, an additional field test must be done by the service agent at least annually to determine if the accumulated sludge is bulking and to indicate whether the aeration compartment/s require desludging. The sludge bulking test is commonly referred to as a Sludge Volume Index (SVI<sub>30</sub>) Test, which gives an index in terms of mL/g. The SVI<sub>30</sub> should not exceed 200 mL/g and should preferably be about 150 mL/g.

To do the SVI<sub>30</sub> Test, collect a sample of at least 1 litre capacity of mixed liquor from the first or primary aeration compartment. Decant the sample into a 1 litre measuring cylinder, which is then allowed to stand for 30 minutes to permit the suspended solids to settle, then measure the quantity of settled solids. Check the sample at 10-minute intervals to determine the rate of settlement and the density of the solids. The rate of settlement indicates the maturity of the plant and the adequacy or inadequacy of the volume of air being supplied and taken up. The quantity of settled solids and its density after a 30 minute settling period indicate whether the plant is operating within its design parameters or accumulating an excessive quantity of sludge and is in need of desludging.

- a service report sheet should be completed for each service. The service report should be in triplicate and must specify all service items and tests results, the amount of chlorine compound provided, the date, and the technician's initials. The original should be given to, or left for, the owner, the duplicate forwarded to the local council, and the triplicate retained by the service agent.

### Local Council Service Control

Because servicing is vital to the operation of the AWTS, a **condition of approval** for installation should be that the applicant must enter into an annual service contract. If there is a change in service agent, the local council should be notified.

**The local council should authorise each service agent to operate in its area.** A service agent training and accreditation scheme is currently being considered by NSW Health.

The local council should establish and maintain a register or data management system of completed service sheets to make it easy to check that servicing has been carried out.

Checks can be done at irregular intervals as a surveillance activity.

If servicing is not being done because the owner or occupier has not renewed or obtained a service contract, then the only recourse is to require the applicant, occupier or owner (the person entering into the annual service contract) to comply with the condition of approval. Local councils should consult Orders 15, 22, and 30 of section 124 of the *Local Government Act 1993*.

Alternatively, the local council may establish its own service agency to control servicing of AWTS in its area effectively. This action is recommended, and it has been introduced competitively by some local councils.

### Advantages

- accidental or deliberate discharges are less detrimental to the environment and have less potential to adversely impact on health
- a higher quality effluent is produced
- a variety of AWTS are commercially available
- treated and disinfected wastewater can be re-used by surface irrigation
- irrigation systems usually have a longer life than soil absorption systems
- as the volume of the system is large, it can better equalise flows and cope more easily with limited shock loadings

### Disadvantages

- high installation cost
- need to establish a large irrigation area
- effluent quality needs to be monitored
- relatively high energy requirement
- additional tanks could be needed for aeration, disinfection and irrigation
- high maintenance requirements
- maintenance contract required
- mechanical or electrical (blower and/or pump) failure inactivates the AWTS
- affected by household chemicals
- chemical pollutants (and nitrogen and phosphorus) remain
- inadequate disinfection or disinfection failure still poses a health risk to house occupants and pets
- water conservation is essential.



### 5.3.4 WATERLESS COMPOSTING TOILETS

Waterless composting toilets are designed to receive human excreta and organic household kitchen scraps. Sometimes a hand-basin may be connected when the waterless composting toilet discharges excess water to a land application system.

#### Treatment Process

While all waterless composting toilets rely on the principle of composting by microorganisms, there are essentially two ways in which this is achieved. The first is by collection and composting of human excreta in a single chamber on a screen that is raked at its base to remove the compost. The second is by collection and composting of human excreta in separate compartments.

The advantage of the waterless composting toilet is that a water supply is not needed for its operation. However, the water content of the compost heap is critical for efficient and odourless operation. Also, while the composting process generates some heat, rapid loss of heat and low temperatures reduce the effectiveness of composting. In cold climates the process might stop unless insulation or a heating element is provided.

In a **single chamber** waterless composting toilet, human excreta is deposited directly down a chute or through an opening and on to the compost heap. There is no flushing mechanism and no water seal, so it is important that the lid be in place to control fly breeding when the closet is not in use. Biodegradable food scraps may be added to the compost heap to help the decomposition process by adding organic matter and reducing moisture. Worms may also be added to help the decomposition process. The deposited material is detained on a screen, which allows the excess moisture to pass through and be collected in a tray below. It might be necessary to activate a spreader to ensure that newly deposited material is evenly spread over the compost heap and remains clear of the chute.

Microorganisms such as bacteria and moulds attack the heap and gradually compost the material to humus. The composting time depends on moisture, air and temperature in a positive association. Too much moisture can result in odour production; a mechanism can be installed to evaporate excess moisture. A ventilation pipe must be installed and excess moisture might need to be drained to a treatment system and land application area.

As the heap increases in height, the base of the heap gradually converts to compost or humus over a period of months. In some models the heap might need to be raked to remove humus before the compost is applied to land. Humus is removed through a separate hatch or doorway, not through the chute.

**Figure 4: Cross-Section of a Single Chamber Waterless Composting Toilet**

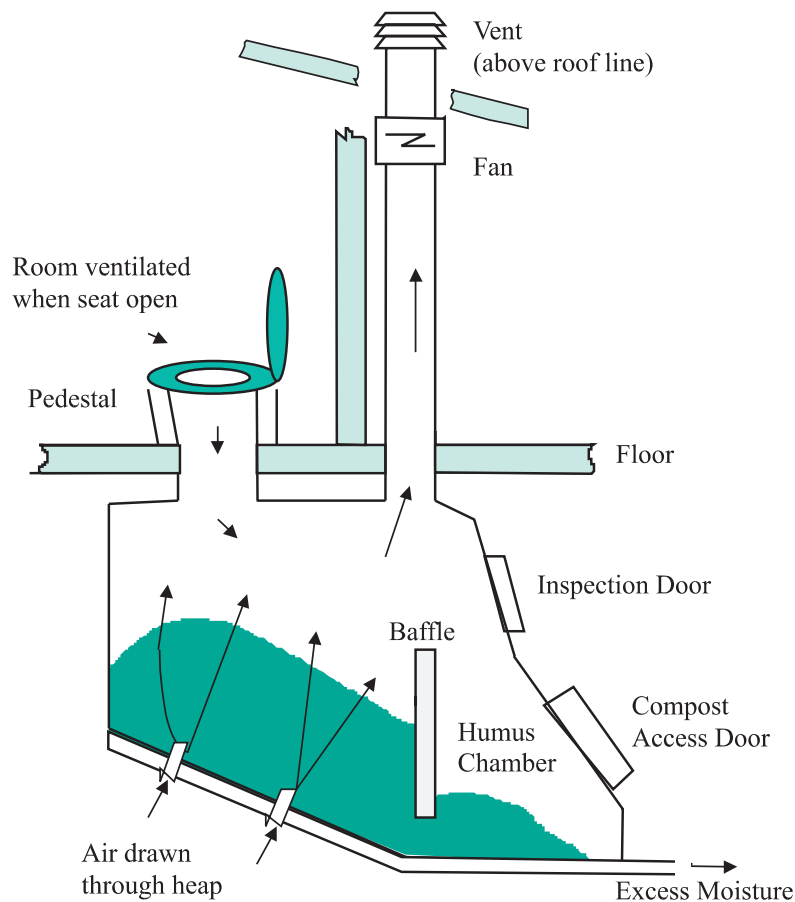

This type of waterless composting toilet is subdivided into two categories: free-standing and integral. Small units tend to serve a maximum of three people and be free-standing in a room constructed for that purpose. Large units require a sub-floor area in which to locate the composting chamber. The depth of sub-floor required can influence the design of the dwelling or require the construction of separate closet facilities for an existing dwelling. With some models, an electricity supply is required to operate a fan or heating element.

There are two types of **multiple chamber** waterless composting toilets. Both are based on the same principles of composting as described above. Once a chamber has been filled with material the chambers are switched or rotated. In one type, this is achieved by revolving a multi-chambered drum, and in the other, by relocating the chute over the other chamber. Composting continues to completion without further material being added to the compost heap. The dates when the drum is revolved or the chute position switched need to be written down.

## NSW Health Certification

All composting toilets that are to be mass produced, or whose standard plans are to be distributed, must be tested by the manufacturer using an independent organisation for compliance with NSW Health protocols.

Companies marketing these systems will also have to set up quality assurance systems for consumer confidence. Full and detailed specifications for the waterless composting toilet must be supplied by the manufacturer to each local council where it is intended to market the product. This helps the local council to do detailed inspection for compliance with certification immediately after installation.

## Local Council Approval

Local councils may conditionally approve waterless composting toilet installations. A list of conditions commonly used by local councils is attached as Appendix 5. The council should select and apply the appropriate conditions, together with any other condition the local council may wish to apply. **It is important not to neglect greywater management, and a suitable system should be designed for this purpose too.**

## Installation

Installation should be done by representatives or contractors of the distributors of the waterless composting toilet. Particular attention should be paid to the ventilation of the unit, fly control measures and screens, and the initial start-up procedure. It is usual practice to charge the base of the composting closet with layers of dry and strong organic material, such as biodegradable paper, sawdust, or other absorbent material. This is to ensure that the humus develops above the grate or screen and does not fall through to the liquid detention chamber.

A separate purpose-built closet structure might be required if the building design does not permit installation of the vessel below the floor level. The layout of the installation should make proper maintenance of the toilet easy, and thus help ensure successful operation. This includes provision of convenient, safe, and ergonomically correct access to the unit and compost storage area.

## Maintenance

Maintenance is the responsibility of the owner or occupier and is not normally subject to a maintenance contract. **The owner or occupier must be committed to the principles of composting.** Maintenance varies among waterless composting toilets, and the maintenance requirements need to be specified clearly in a manual.

The manual should cover all the aspects of efficient humus production, and should specifically include the following:

- the control of excessive moisture production in the waterless composting toilet vessel
- procedures to ensure that the deposited material is spread evenly over the base of the waterless composting toilet
- cleaning procedures (eg. minimal use of water and disinfectants on pedestal)

- procedures for removing compost
- procedures to eliminate the production of odours
- procedures to ensure that material does not block the base of the chute.

## Service Requirements

Service requirements are mainly those recommended by the manufacturer, and the replacement of defective parts such as fans or heating elements if they are fitted.

## Compost Management

Composted humus should be removed by the occupier or a contractor for management only after the minimum composting period has elapsed. Composted humus should be removed only through the access door (where provided) or from the humus storage tray, and it may be applied only to land within the boundaries of the premises unless the written approval of the local council has been obtained for an alternative method.

The composted humus from the humus closet must not be applied to land directly in an area used for the production of root crops for human consumption. The compost should be buried under clean friable soil in a level area not subject to erosion or inundation, and at a minimum depth of 75 mm below finished ground level.

After 3 months' maturation below ground level **or** maturation in a separate lidded compost bin providing aeration and without further addition, the composted humus may be used in the garden, but not for the production of crops that are consumed raw.

## Advantages

- conserves water
- can handle a shock loading
- can be installed in adverse site conditions
- reduces solids carryover to the land application system
- recycles nutrients

## Disadvantages

- high capital costs
- some energy consumption if fan and/or heater installed
- handling of waste is required
- does not function well in cold temperatures
- greywater has to be managed separately
- moderate to high maintenance required
- aesthetically unappealing to some people
- may require a purpose-built structure to house unit
- requires a persistent commitment to composting principles.

### 5.3.5 RECIRCULATING AEROBIC SAND FILTER DEVICES (RASFD)

A recirculating aerobic sand filter device (RASFD) further treats the effluent from a septic tank.

#### Treatment Process

Effluent is collected in a sump or holding well and is pumped intermittently for distribution through a bed of coarse sand in a similar way to that of a trickling filter. The treated effluent returns to the sump for recirculation. A diversion valve is placed in the return line to the sump, and the effluent is used in a land application system. The effluent may be disinfected for above-ground use. The quality of the effluent is better than or similar to that from an AWTs.

Aerobic sand filter devices that do not recirculate wastewater are not subject to NSW Health accreditation, but form part of the land application system and are considered as ancillary systems later in this section.

#### NSW Health Certification

All RASFD must be tested by the manufacturer using an independent organisation for conformity to NSW Health protocols contained in guidelines that are being prepared.

Companies marketing RASFD will also be required to set up quality assurance systems for consumer confidence. Full and detailed specifications for the RASFD must be supplied by the manufacturer to each local council where it is intended to install the RASFD. This helps the local councils to do detailed inspections of the RASFD for conformity to certification immediately after installation.

#### Local Council Approval

Local councils may approve of RASFD installations conditionally and should require strict compliance with the design and manufacturers' recommendations for operation and maintenance.

#### Installation

It is imperative that the local council does a detailed inspection of the installed RASFD and the land application system before commissioning.

#### Operation

As RASFD treat septic tank effluent, the operational parameters are similar - see the section on septic tanks.

#### Maintenance

Maintenance is in accordance with the section on septic tanks. Additionally maintenance of the RASFD should follow the manufacturer's recommendations, particularly those relating to the occasional clogging of the filter due to slime accumulation.



## Advantages

- may be used to improve effluent to extend the life and effectiveness of the land application system
- high quality effluent is produced
- can handle surge loads
- low maintenance
- improved resource use

## Disadvantages

- energy consumption
- adds expense to septic tank system
- sand may not be available locally
- water conservation is essential.

### 5.3.6 WET COMPOSTING TOILETS

#### Treatment Process

A wet composting toilet functions in a similar manner to a waterless composting toilet in that it uses an aerobic composting process, but it receives all of the household wastewater and putrescible household organic solid wastes, such as vegetable peelings and waste food residues. The toilet pedestal can be either flushing or non-flushing. The organic wastes form a pile in the centre of the composting vessel, which serves as a filter for liquid wastes. The composting process relies on micro-organisms, worms, beetles and mites to work over the pile; this greatly accelerates the aerobic process. The worms, beetles and mites need to be seeded into the vessel. The composting process produces a large reduction of volume, which means that compost removal should not be necessary for the first five years of operation.

The filtered wastewater is collected at the base of the vessel and either fed by gravity or pumped to a land application area. The treated wastewater typically has a reduced BOD and suspended solids of less than 100 mg/L, but is still infectious and high in nitrates and phosphates.

#### NSW Health Certification

All wet composting toilets must be tested by the manufacturer using an independent organisation for conformity to NSW Health protocols, which are currently being drafted.

Companies marketing these systems will also have to set up quality assurance systems for consumer confidence. Full and detailed specifications for the wet composting toilet must be supplied by the manufacturer to each local council where it is intended to market the product. This makes it easier for the local council to do detailed inspections of the wet composting toilet for conformity to certification immediately after installation.

## Local Council Approval

A local council may not approve an installation of a wet composting toilet unless it has been certified by NSW Health. An inspection of the completed installation should be done to ensure that appropriate conditions of approval have been satisfied.

## Installation

The installation should be done by representatives or contractors of the distributors of the toilet. Particular attention should be paid to the ventilation of the unit, fly control measures and screens, and the initial start-up procedure. It is the usual practice to charge the base of the toilet with layers of dry and strong organic material, such as biodegradable paper. This is to ensure that the compost develops above the grate or screen and does not fall through to the liquid detention chamber.

Because the composting vessel must be built or located below the floor level for an integrated installation, the building design needs to allow for such an installation, and a sloping site would be an advantage. Alternatively, the toilet might need to be located in a purpose-designed outhouse.

**Figure 5: Cross-Section of a Wet Composting Toilet**

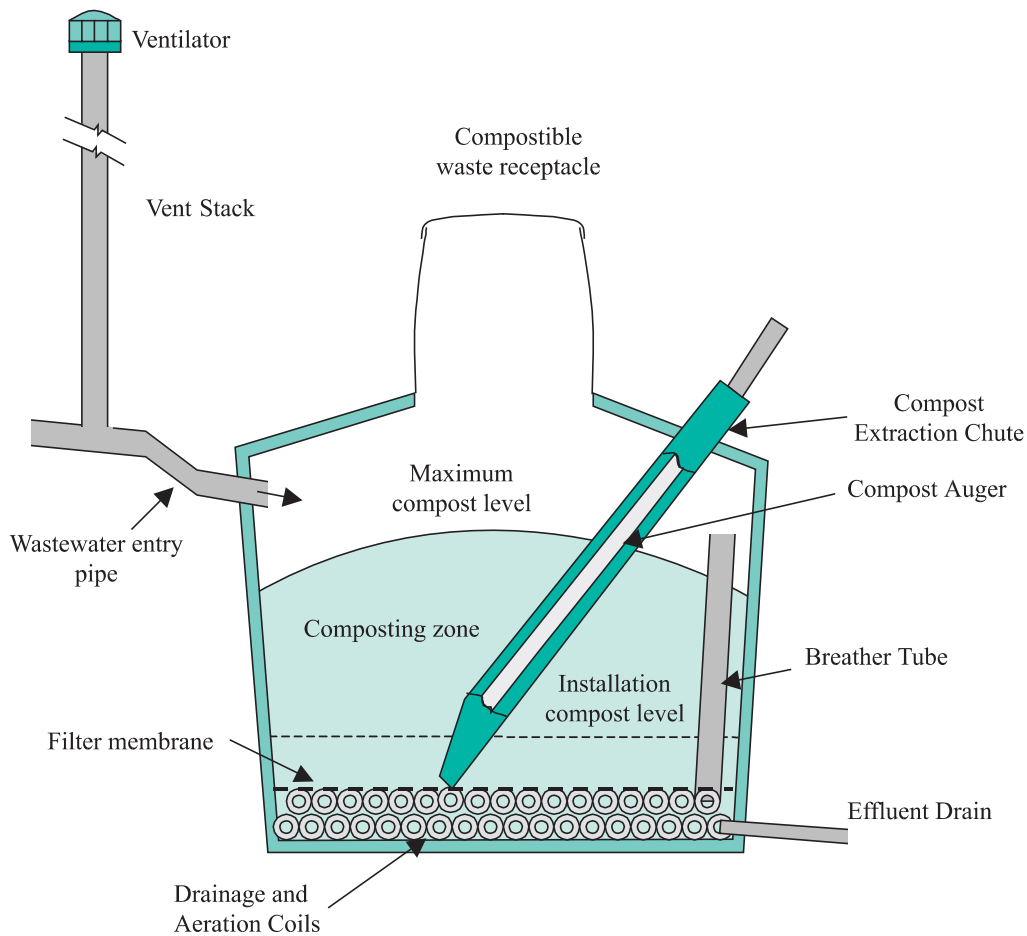

## Operation

Because the wet composting toilet depends on a sensitive ecological and biological process, chemicals that might alter the ecological balance should not be discharged to the system. The details for operation specified by the manufacturer must be followed explicitly.

## Maintenance

Maintenance is the function of the owner/occupier and is not normally subject to a maintenance contract. **The owner/occupier needs to be committed to the principles of composting.** Maintenance needs can vary among wet composting toilets, and they must be specified clearly in a manual.

The manual should include all those aspects relating to the efficient production of compost and should specifically include procedures for the following:

- ensuring that the deposited material is spread evenly over the base of the wet composting toilet
- ensuring that the grate or screen is intact
- cleaning
- removing compost
- eliminating the production of odours
- ensuring that material does not block the base of the wastewater entry pipe
- ensuring correct use of wastewater.

## Service Requirements

Service requirements are mainly those recommended by the manufacturer, and the replacement of defective parts such as fans or heating elements if they are fitted.

## Compost Management

Composted humus should be removed by the occupier or a contractor for management only after the minimum composting period has elapsed. Composted humus should be removed only through the access door or auger (where provided) and may be applied only to land within the boundaries of the premises unless the written approval of the local council has been obtained for an alternative method.

The composted material from the wet composting toilet must not be applied directly in an area used for the production of root crops for human consumption. The compost should be buried under clean friable soil in a level area not subject to erosion or inundation, at a minimum depth of 75 mm below finished ground level.

After three months' maturation below ground level **or** maturation in a separate lidded compost bin providing aeration and without further addition, the composted humus may be used in the garden, but not for the production of crops that are consumed raw.

## Advantages

- helps conserve water
- can handle some shock loading
- may be installed on difficult sites but where there is adequate land available for treated wastewater use
- reduced carryover of solids to the land application system
- recycles nutrients

## Disadvantages

- high capital cost
- moderate operational requirements apply
- treated wastewater still needs to be managed
- aesthetically unappealing to some people
- may require a purpose-built structure to house the unit
- water conservation is essential.

### 5.3.7 COMBUSTION TOILETS

A combustion toilet is a permanent or temporary installation where human waste is incinerated.

#### Function

A metal pan is lined with paper upon which the human excreta is deposited. Once the lid has been closed it locks until the incineration is complete. The toilet uses bottled liquid petroleum gas and an auto-ignition device to direct a flame to incinerate the human excreta. During the incineration phase further use of the toilet is prevented until the metal pan has cooled.

#### NSW Health Certification

Only one such toilet brand has been certified on its own merits in NSW. Guidelines for further certification are in the process of being drafted and should be available during 1998.

#### Local Council Approval

Local council approval for the installation of combustion toilets as human waste treatment devices is required. The possible hazardous area created by such a device (such as in the gas bottle location) should be recognised prior to approval.

#### Installation

The combustion toilet should be inspected and tested (using suitable organic material) by the installer before it is allowed to be used.

As there is usually an odour associated with incineration of human excreta, this device would be suitable only for installation in remote areas, particularly where it may be difficult to dispose of or use treated effluent or compost.

### Operation

Operation involves simply using the toilet and closing the lid. The toilet should not be used to incinerate any other wastes. Safety procedures should be observed in the gas bottle location.

### Maintenance

The unit should be maintained in accordance with the manufacturer's instructions, and the gas bottle filled regularly.

### Advantages

- destroys the human waste, leaving a small ash residue
- no land application system needed for blackwater

### Disadvantages

- energy requirement
- generates odours
- users may have to wait a considerable time to re-use the toilet
- capital investment required
- cannot be used when the gas bottle is empty
- separate greywater management system required

## 5.3.8 ANCILLARY SYSTEMS

After the wastewater treatment process is finished, pollutant levels in the wastewater should be reduced to a level that is readily manageable. However, effluent from some treatment systems may still be biologically active and contain high levels of pollutants.

Recently there have been developments in the area of ancillary on-site sewage management systems. These systems can be added to the main treatment train with the objective of improving the effluent quality, and so enabling the treated wastewater to be managed in a larger number of ways. These ancillary systems are not considered to be treatment systems requiring certification by NSW Health. At this stage they are considered optional, but they are worth consideration by local councils.

However, because of the large number of system variations available, when local councils are issuing approvals they can have difficulty ensuring that systems will perform well in the long term. There might be little or no design or sizing, maintenance and performance data available for new systems.

Ancillary systems should be installed only after full consultation with the local council. It is important that users understand and abide by operational and maintenance requirements.

The following are some examples of ancillary systems that might be available.

### Constructed Wetlands - Reed Beds

Constructed wetlands and reed beds are purpose-built areas where the water surface is near ground level for enough of the year to maintain saturated soil conditions and promote growth of vegetation. Constructed wetlands may be used further to treat wastewater that has undergone secondary treatment (such as through an AWTS) before land application.

**Free water surface wetlands** consist of emergent, submerged or floating native aquatic vegetation in a shallow bed or channel, with the water surface exposed to the atmosphere. Wastewater should be adequately disinfected before it is applied to a free water surface wetland.

**Subsurface flow wetlands (reed beds)** contain at least 30 cm of permeable media, such as rock, gravel or coarse sand, which supports the root system of the emergent vegetation. The treated wastewater flows through this medium and is not in direct contact with the atmosphere.

Constructed wetlands can be effective sediment traps and good sites for the breakdown of organic material. Their performance in removing nutrients is less predictable. Long-term removal of nitrogen is possible in some cases, but phosphorus removal is unreliable. Under some conditions these systems can even release nutrients to the wastewater.

The parameters that enhance wetland performance and system reliability are currently not well known, and there are no generally accepted design criteria for constructed wetlands. Design, installation and management requirements are therefore not specified in these guidelines. Management could include regular vegetation harvesting and replacement of the root support medium at appropriate intervals throughout the whole life of the system.

### Amended Soil Systems

Amended soil may be used further to treat wastewater that has undergone primary or secondary treatment (such as through a septic tank or AWTS) before land application.

Systems are usually constructed on an impermeable membrane, with the septic effluent flowing through the amended soil medium. Systems can promote evapotranspiration from the amended soil, with any remaining water directed to a separate land application system.

Amended soil systems can achieve high removal efficiencies for biochemical oxygen demand (BOD), suspended solids (SS), nutrients and pathogens.

### Sand Mounds - Sand Filters

Sand mounds and filters can be used further to treat wastewater that has undergone primary or secondary treatment (such as through a septic tank or AWTS) before land application.

They use a combination of biological processes and adsorption to achieve results similar to those from amended soil systems.

### 5.3.9 GREYWATER TREATMENT DEVICES

It has become popular to collect or divert greywater from the laundry, bath and shower (kitchen greywater is usually excluded) and apply it to gardens and lawns. However, greywater can be infectious, and without disinfection it must not be used above ground. Simply disinfecting the greywater is rarely successful in the long term unless the greywater or the soil has also been treated to improve percolation. This aspect is not considered in these guidelines - separate advice should be sought from the local water authority or a soil scientist. The long-term successful application of greywater to soil may be difficult to achieve, because the greywater is rich in sodium (a by-product of detergents), which may affect the absorptive properties of the soil.

A greywater treatment device collects and treats greywater from the laundry, bath and shower for subsurface land application. When adequately treated and disinfected it may be used for other purposes such as toilet flushing, car washing (on grassed areas) and above-ground irrigation. Take care to ensure that the irrigation system does not produce an aerosol spray. There is a greater range of greywater re-use options because blackwater (human excreta) as a wastewater source is excluded from the wastewater stream.

A greywater treatment device, as distinct from a greywater diverter, treats greywater to a similar standard as an AWTS. A NSW Health policy for the diversion, use and re-use of greywater is currently being drafted.

Rainwater collection and use in metropolitan areas could be a more cost-effective alternative for lawn and garden irrigation.

#### **NSW Health Certification**

Greywater treatment devices (not diversion appliances) must be certified by NSW Health. Preliminary applications have been received for certification of greywater treatment devices. Guidelines for assessment and approval are currently being drafted by NSW Health and should be available during 1998.

#### **Local Council Approval**

Local councils may not approve of the installation of greywater treatment devices unless they have been accredited by NSW Health. An inspection of the completed installation should be done by the local council to ensure that appropriate conditions of approval have been satisfied.

#### **Installation**

Installation is similar to that for an AWTS.

## Operation

Greywater treatment devices are similar to AWTs and require similar operation. In particular, they are susceptible to the effects of many household chemicals; such chemicals should be used sparingly.

## Maintenance

Devices producing effluent suitable for subsurface application are less complicated and require rudimentary maintenance of the filter and replenishing the disinfectant source where a chemical disinfectant process is used. As greywater treatment devices become more mechanically complex they require more intensive maintenance. To use devices producing effluent suitable for above-ground application, the householder must enter into a maintenance contract in the same way as for an AWT.

## Advantages

- greywater treatment devices have the capacity to be used in metropolitan and urban areas to allow re-use of a wastewater rather than disposal to sewer
- save on using drinking water on vegetated areas
- high quality effluent can be produced

## Disadvantages

- energy consumption
- need some degree of maintenance and care
- separate management system required for blackwater.

### 5.3.10 DISINFECTION

The micro-organisms capable of causing disease range from viruses, bacteria, protozoans and multicellular organisms. Because bacteria are needed to digest food in the intestines of humans, they multiply rapidly in the human gut and are excreted in large numbers. Bacteria excreted by humans tend to be human host-specific, and therefore have the greatest potential to cause disease in humans.

**Disinfection** is the process of destruction, inactivation or removal of pathogenic (disease causing) micro-organisms, unlike **sterilisation**, which is the destruction of all micro-organisms. It is impossible to sterilise effluent, as difficulties arise in ensuring that all pathogens are destroyed. Instead of analysing for individual pathogenic organisms, samples are taken and analysed for bacteria known as faecal coliforms, which indicate the likely presence of other pathogenic bacteria. While disinfection is an important barrier to disease transmission, it should not be relied upon as the only barrier. It is therefore important to build other barriers into the design and management of the land application system.

Disinfection of treated wastewater is required if there is a high risk of human contact with the wastewater. With respect to on-site systems, disinfection is required if the treated



wastewater is to be applied to the land surface. Disinfection of untreated wastewater is ineffective, because the organic matter inactivates the disinfection agent and protects the pathogens from the disinfection process. Disinfection becomes effective only when wastewater is treated to a high standard.

Pathogens that can survive disinfection processes are common in the Australian environment, and include parasites such as *Cryptosporidium* and *Giardia*, as well as a number of viruses known to cause gut infections (such as Norwalk virus and rotavirus). Their presence needs to be considered when public health risk assessments are being done for large developments relying on on-site sewage management. Many disinfection methods are not very effective against protozoan cysts, viruses and bacteria that adhere to particles. Hence it is important to reduce the levels of suspended solids to improve the disinfection efficiency.

The number of organisms required to cause disease varies; often only a few virus particles or protozoa are enough to cause a disease, but many bacteria are required. Some bacteria that cause gastrointestinal infection need to be present in their thousands to cause infection and symptoms. The infective dose also varies among people because of their individual susceptibility. The most susceptible are the very young, often because they have poor personal hygiene; the frail and elderly, often because they have declining immune systems; and the sick because they have compromised immune systems.

The most important and effective barrier to infection is to prevent exposure of people to contaminated material. Therefore, from a public health point of view, the most favoured option is a wastewater system that takes infectious waste away from people and places a barrier between the people and the waste so that they will have no further contact with it. Under these circumstances, it is not so important to have to rely on disinfection.

Chlorination is the main method of disinfection practised for domestic application, but alternative techniques, such as the use of ultraviolet light, ozone or microfiltration, can be considered.

## Chlorination

Disinfection by applying a chlorine-based chemical to wastewater (chlorination) is currently the main method used in domestic on-site systems. Chlorination effectiveness depends on the BOD, suspended solids (SS) and ammonia concentrations of the treated wastewater. Low SS concentrations are required for the best chlorination efficiency. The efficiency of the disinfection depends on the contact time and concentration; in wastewater treatment, disinfection is ideally achieved during a contact period of 30 minutes at a concentration of 1 mg/L of free chlorine.

The most usual chlorination method is to employ di- or tri-chloroisocyanurate tablets in an erosion feeder, followed by at least 30 minutes in a contact tank. The chlorine dosage rate must be sufficient to ensure bacterial kill and enough residual chlorine concentration to prevent regrowth of pathogens. The design of chlorination facilities must ensure that short-circuiting of the wastewater flow does not occur. Disinfected wastewater then flows into a separate irrigation storage tank before land application.

Performance objectives:

- free chlorine: 0.5 - 2.0 mg/L
- faecal coliforms <30 cfu/100 mL
- contact period 30 minutes

In the field, it is apparently not easy to achieve the above performance objectives consistently. Physical contact with all wastewater should be minimised and hygienic practices observed.

Some plants and organisms in the environment are chlorine-sensitive, and chlorine can be considered to be a pollutant. Excessive use of chlorine should be avoided.

### Other Disinfection Technologies

Other forms of disinfection have been proposed, including ultraviolet light (UV), ozone and microfiltration. These have the advantage of not leaving chemical residuals in the final effluent.

#### Ultraviolet Light

UV light disinfection involves exposing pathogens to a particular wavelength of UV light over a particular length of time - that is, the efficiency depends on the exposure time and dosage strength. Also, to make sure the micro-organisms are exposed to the light, they must not be shielded by particulate matter and slime growth on the lamps, so a very high quality effluent and regular lamp maintenance is required.

#### Ozone

Trials using ozone have been done, but they were not very successful. Again, successful disinfection is time- and concentration- dependent. The reason for the failure to disinfect is not known, but it was believed to be associated with poor dispersal of ozone, its deactivation by organic matter, or its lack of contact with the micro-organisms.

#### Microfiltration

Microfiltration is hailed as the next available technology that could be used for disinfection. The technology uses selective membranes, which allow only molecules below certain molecular weights to pass through. Problems encountered include overgrowth of a microbial layer (which reduces the effectiveness of permeability) and the need to apply a special backwashing technique. Microfiltration needs further development before it can be readily used in domestic wastewater disinfection, but its clear advantage is that no residual chemicals would be added to the final effluent.

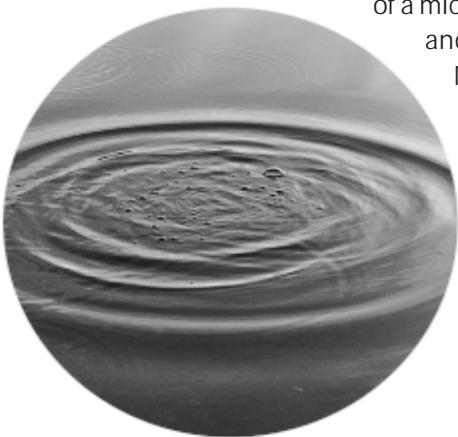

## 5.4 ON-SITE LAND APPLICATION SYSTEMS

### 5.4.1 GENERAL CONSIDERATIONS

Land application involves applying treated wastewater at a specific loading rate to vegetated land. This application can be above or below ground level and in existing or imported soil.

Wastewater requires varying levels of treatment, depending on the method of land application and the sensitivity of the site. Treated wastewater applied above-ground must be adequately treated and disinfected, but if it is applied below-ground it does not always need to be disinfected. Below-ground application is preferred, as it minimises the public health risk associated with inappropriately disinfected wastewater. Complete separation of humans and animals from all wastewater, regardless of whether it has been disinfected, is the best barrier to ensure public health protection.

The degree of wastewater treatment required for different land application systems is shown in Table 15.

**Table 15: Degree of Treatment Needed for Land Application**

Treatment	Device Type	Land Application System
Primary	<ul style="list-style-type: none"> <li>• Septic Tank</li> <li>• Greywater Tank</li> <li>• Waterless composting toilet</li> <li>• Wet composting toilet</li> <li>• Combustion toilet</li> </ul>	<ul style="list-style-type: none"> <li>• Soil absorption systems</li> <li>• Burial (for compost)</li> </ul>
Secondary	<ul style="list-style-type: none"> <li>• AWTS</li> <li>• Greywater treatment</li> <li>• Septic tank and recirculating sand filter</li> </ul>	<ul style="list-style-type: none"> <li>• Subsurface irrigation</li> </ul>
Tertiary (disinfection)	<ul style="list-style-type: none"> <li>• AWTS</li> <li>• Greywater treatment</li> <li>• Septic tank and recirculating sand filter</li> </ul>	<ul style="list-style-type: none"> <li>• Subsurface irrigation</li> <li>• Surface irrigation (non-aerosol)</li> </ul>
Greywater tertiary (excluding kitchen wastes)	<ul style="list-style-type: none"> <li>• Greywater treatment</li> </ul>	<ul style="list-style-type: none"> <li>• Subsurface irrigation</li> <li>• Surface irrigation (non-aerosol)</li> <li>• Toilet flushing</li> </ul>

Consider using dual (split) application areas, this allows adequate resting (return periods) between periods of treated wastewater application; for example, two soil absorption areas or two irrigation areas can be used alternately. In sensitive locations, land application areas might need to be lined with impermeable material to stop treated wastewater percolating through the soil. The design and management of the system should always be such that treated wastewater is applied at the rate at which it is used or at a rate that will not cause pollution.

During the various stages of land use planning, there are many factors to consider in wastewater use, both at the micro level (individual systems) and at the macro level. It is vital to consider whether the land is capable of sustaining on-site management; if it is not, consider other management methods, such as partial on-site or total off-site.

### Suitable Vegetation

Large trees should **not** be planted on land application areas. Roots can interfere with the functioning of subsurface irrigation systems and soil absorption systems, and the shading of surface irrigated areas can reduce the evaporation (although this might sometimes be offset by an increase in transpiration). Plant large trees at a distance from the land application area that is equivalent to the expected tree height. Shrubs, ground covers, sedges and grasses that grow to 0.5 - 1 metre are appropriate to plant in land application areas.

See Appendix 7 for a list of the types of vegetation recommended for land application and buffer areas. People in rural areas can contact their local branch of the Australian Plants Society for further information.

### Hydraulic Loading

Hydraulic loading is the amount of liquid applied to land over a specified time interval. It can be expressed as either a depth or a volume (with one millimetre of application equal to one litre per square metre). The hydraulic loading rate must be such that surface ponding, run-off and excessive percolation of the treated wastewater does not occur. Calculating a water balance allows estimation of the area required for irrigation systems and wet weather storage of wastewater (see Appendix 6). An appropriate hydraulic loading rate for soil absorption systems can be determined from analysing the structure and texture of the soil.

### Nutrient Loading

Nutrient loading is the amount of nutrient (usually phosphorus or nitrogen) applied to land over a specified time period. If more nutrients are added than can be removed, they can be transferred to ground and surface waters and can cause adverse environmental and health effects.

### Nitrogen

Nitrogen can be present in treated domestic wastewater in organic forms such as amino acids and protein, and inorganic forms such as ammonia ( $\text{NH}_3$ ), ammonium ion ( $\text{NH}_4^+$ ), nitrate ( $\text{NO}_3^-$ ) and nitrite ( $\text{NO}_2^-$ ). The forms of nitrogen present depend on the treatment processes employed. About 40% of the nitrogen is usually present as organic nitrogen, with the remainder as ammonia or ammonium ions. Nitrogen is removed through a complex set of processes, which depend on the site factors and the form of the nitrogen. Nitrogen removal mechanisms include:

- vegetation uptake (major removal mechanism)
- volatilisation
- denitrification
- soil absorption (limited and reversible).

Organic nitrogen associated with suspended solids can be removed by sedimentation and filtration, while some is hydrolysed to soluble amino acids. These can undergo further breakdown to release ammonia. Soluble ammonia may be volatilised into the air, although this is a minor removal mechanism. Ammonia can also be temporarily adsorbed on soil particles, and is therefore available for vegetation uptake and nitrification.

Denitrification is done by facultative bacteria in soil under largely anoxic (without oxygen) conditions, although even in aerobic (with oxygen) conditions 15 - 25% of the applied nitrogen can still be denitrified. A carbon to nitrogen ratio of two to one is required for maximum denitrification. Nitrate is highly soluble, and if it is not used by vegetation or removed by denitrification, it can percolate through the soil profile and reach ground and surface waters - an unacceptable situation.

Of greatest concern is the pollution risk posed by high nitrate levels. Nitrates are not adsorbed, or physically retarded, by the soil, and can therefore travel large distances in soils if they are not used by vegetation. Using soil absorption systems with septic tanks can therefore lead to nitrate pollution of groundwater, unless they are installed at a very low density within a catchment or aquifer.

## Phosphorus

Phosphorus can be present as orthophosphate, polyphosphate and organic phosphate. Removal mechanisms depend on the site factors and the form of the phosphorus. The orthophosphates are available immediately for biophysical reactions in the soil - plant system. The availability of polyphosphates is limited by their hydrolysis, which proceeds very slowly in most soils. Organic phosphates are broken down biologically to polyphosphates and then to orthophosphates.

Phosphorus removal mechanisms in land application systems are:

- vegetation uptake (minor removal mechanism)
- chemical precipitation
- adsorption to soil particles (major removal mechanism; not readily renewable).

Chemical precipitation occurs with calcium in neutral to alkaline soils, and with iron and aluminium in acid soils. Chemical precipitation occurs at a slower rate than adsorption.

The orthophosphates readily adsorb to clay minerals and certain organic soil fractions. The soil phosphorus sorption capacity can be measured; it gives an estimate of the amount of phosphorus that may be adsorbed by the soil before the site is saturated. Phosphorus adsorption is a strong bond, which is generally resistant to leaching. However, soils are generally only able to sorb around one quarter to one half of their total sorption capacity before leaching of phosphorus begins to occur.



The presence of a even a small amount of phosphorus can stimulate a large mass of cell growth, so any reduction in the level of phosphorus in wastewater can extend the life of the land application area and reduce the amount of vegetative growth there. Consequently, using low-phosphorus household detergents and other cleaning products will help in on-site sewage management.

### Organic Matter Loading

Organic matter loading is the amount of organic matter applied to land over a specified time interval. The amount of organic material in effluent is usually expressed as biochemical oxygen demand (BOD).

Soil organic matter affects soil fertility. The amount of organic matter in soil does not remain constant; fresh additions of organic material are continually broken down by soil micro-organisms. The dark organic material remaining after decomposition is called humus. The presence of humus is essential to maintain soil structure, increase the water-holding capacity of soil and remove nutrients from the treated wastewater.

The BOD in treated domestic wastewater is generally low enough to avoid short-term effects on soil and vegetation. Overloading with organic matter can clog soil pores, favour anaerobic microbiological populations in the soil, and limit the life of the land application area.

Maximum breakdown of organic material occurs under aerobic conditions, as aerobic micro-organisms produce more rapid and complete decomposition and are less odorous than anaerobic micro-organisms.

Calculations of land area requirements based on critical BOD loading rates show that the organic matter loading is generally not a limiting factor for the size of the land application area for treated domestic wastewater.

### Suspended Solids (SS)

Almost complete removal of the SS by filtration and accumulation can be expected when the treated wastewater is applied to land at the acceptable hydraulic loading rate, based on evapotranspiration. If SS are present at high concentrations they will tend to clog and block soil pores and distribution systems; if they are applied above-ground they will tend to coat the leaf surfaces.

### Pathogens

The survival time of pathogens in soil ranges from a few hours to many months. Factors influencing survival include:

- the type of organism - some organisms form long-living spores or cysts and can be protected by slime layers
- the number of organisms - larger concentrations can take longer to die off
- the pH of the soil - this can affect the viability of the organisms
- the available nutrients present and the competition from other micro-organisms
- the climate - rainfall, humidity, aspect, temperature, exposure to UV light
- the soil characteristics.

Bacteria and viruses can migrate, and have been found to cause problems when either the watertable or a horizon of fractured or karst (limestone) bedrock occurs at shallow depths, due to the propensity of these to transfer wastewater large distances. Many viruses can be adsorbed on to soil particles and released at a later stage when the cation exchange capacity of the soil changes.

### Sodium Adsorption Ratio (SAR)

An increase in levels of sodium in the soil can cause clay dispersion and collapse of the soil structure, leading to a decrease in permeability and adverse effects on the vegetation. Any problems with excessive sodium levels can be foreshadowed by testing the sodium adsorption ratio (SAR) of the wastewater.

Treated domestic wastewater can have a sodium adsorption ratio of between one and ten (with an average of about 3.5). For the majority of NSW soils, treated wastewater with a sodium adsorption ratio of less than eight, and an electrical conductivity (EC) of less than 4 dS/m, should not cause problems.

Nevertheless, for effluent to be well absorbed by the soil it is imperative to minimise the sodium loadings in domestic wastewater. This helps to remove the need to restore land application areas after they fail. The cheapest way to decrease the environmental consequences of failed land application areas is decrease the amounts of sodium-containing products entering the wastewater stream before treatment; use low-sodium concentrated liquid detergents.

## 5.4.2 IRRIGATION

Wastewater irrigation systems are based on the principle of use. They rely on natural physical, chemical and biological processes occurring between the treated wastewater and the soil, the vegetation, micro-organisms and the atmosphere to use the various valuable resources in the wastewater.

## Design

### *The Irrigation Area*

When designing an irrigation system it is very important to consider the critical loading rates of the various components in the treated wastewater. The largest irrigation area calculated from considering the hydraulic, nutrient and organic loadings should be used. (See Appendix 6 for a sample calculation and design.)

Treated and disinfected wastewater should be evenly dispersed over all the designated land application area. For appropriate design requirements for irrigation systems see AS 1547.

It is not appropriate under any circumstances to use flood irrigation techniques that concentrate the discharge of treated wastewater in one or a few locations. A single hose or pipe laid on the ground should not be used, even if it is intended to be moved.

For single household systems, irrigation areas should be planted with grasses such as kikuyu, buffalo, ryegrass and couch. Appendix 7 is a list of vegetation suitable for land application areas and buffer zones.

### *Nutrient Loading*

In an irrigation area, nutrients are removed by vegetation, chemical precipitation and soil adsorption. Nutrient removal by vegetation occurs only during the active growth period of the vegetation, and varies greatly among different vegetation types. The wastewater must be available to the root zone of the vegetation for nutrient uptake to occur. Harvesting plants (which may include mowing or pruning) and removing them from the site is required to maintain the nutrient uptake rate. Nutrients retained in a standing crop, detritus, or residual humus must be regarded as potential reservoirs of soluble nitrogen and phosphorus on the site.

The use of phosphorus by vegetation is only a minor removal mechanism. Adsorption on to soil particles is usually the main way that phosphorus is removed from the effluent. This mechanism is not readily renewable, and irrigation areas should have a design life of at least 50 years before the phosphorus sorption capacity is exceeded.

See Appendix 6 for a sample calculation of a minimum irrigation area based on nitrogen, phosphorus and organic matter loadings.

Nutrient balance calculations demonstrate the importance of reducing both the volume of wastewater produced by a household and the concentration of nutrients within the wastewater. The implementation of wastewater and nutrient reduction initiatives such as the use of low phosphate detergents, composting toilets, and water-saving shower heads, taps and appliances, can lead to significant reductions in irrigation area and wet weather storage requirements.



### *Hydraulic Loading*

A water balance can be used to estimate irrigation area and wet weather storage requirements based on climate and wastewater production. It is expressed as:

$$\text{precipitation} + \text{applied wastewater} = \text{evapotranspiration} + \text{percolation}$$

Where:

**Precipitation** refers to deposits of water, either in liquid or solid form that reach the earth from the atmosphere; it can include rain, sleet, snow, hail, dew and frost.

**Evapotranspiration** is the removal of water from soil by evaporation and by transpiration from plants. Monthly evapotranspiration is estimated to be a certain percentage of the monthly evaporation. This percentage is known as the 'crop factor'. The crop factor can vary, depending on the type of plant being grown, the area of the state where the irrigation area is placed, the time of the year, and exposure of the site.

**Percolation** is the descent of liquid through the soil profile, beneath the root zone. A design percolation of 5 mm a week can be used.

See Appendix 6 for an example of a water balance calculation.

### *The Wet Weather Storage Volume*

Wastewater cannot be applied to land during wet weather and whenever the soil is saturated, because of the possibility of surface ponding and run-off. Wet weather storage is therefore required for irrigation systems. This storage must be in enclosed tanks to ensure public health protection.

A water balance can be used to work out the volume of wet weather storage needed for a particular irrigation area size, taking into account the nutrient loading figures, rainfall patterns and optimum irrigation levels. A minimum storage capacity of three days is recommended.

Appendix 6 contains a sample calculation of the wet weather storage required for a site.

Wet weather storage should be designed and constructed in a way that reduces the need for management by householders. Storages should be empty when not being used. It is a good idea to install soil moisture sensors attached to automatic pumps; these ensure that treated wastewater is applied at the appropriate time and rate.

Water balance calculations demonstrate the importance of reducing the amount of wastewater produced by a household. The implementation of wastewater reduction initiatives such as composting toilets and water-saving shower heads, taps and appliances can lead to significant reductions in area and storage requirements.

If calculations show that wastewater cannot be applied to a site for certain periods of the year, the use of off-site sewage management should be considered. This issue must be considered in the early planning stages. If wastewater cannot be applied to land for a significant portion of the year, then on-site sewage management will not be appropriate. Some alternative management options are provided in Section 6.

## Installation

Stormwater run-on should be diverted from the irrigation area. Low-growing crops that are eaten without cooking should not be grown on the irrigation area, and serious consideration should be given to fencing off the area. Signs should be erected to warn people that as treated effluent is being used they should avoid contact or consumption.

The irrigation area should be free from clotheslines, swimming pools, sandpits and BBQ areas. Children, elderly people and animals should be excluded from the irrigation area.

Underground distribution pipes for treated wastewater should be buried at least 100 mm below ground level. Drip, trickle or spray application techniques can be used. Soaker hoses, garden sprinklers and standard water hose fittings must **not** be used. Distribution systems must not be capable of being connected to the mains water supply.

Sprays must be installed to ensure that all wastewater is contained within the land application area and that spray drift will not contaminate active recreational areas and swimming pools. Spray systems should use low pressure, low volume spray heads that produce coarse droplets, with a spray head plume radius less than 2 m, and a plume height less than 0.4m.

Irrigation and buffer areas should be appropriately vegetated. The irrigation system must be fully installed and landscaped before the treatment system is commissioned.

## Operation and Maintenance

The home occupier should regularly check that the irrigation system is operating without run-off, and that all outlets are working satisfactorily. Also, service agents should (as part of each treatment system service call) make sure that any mechanical equipment, soil moisture sensors and the switching between split land application areas are operating correctly. They should also make sure that the distribution system is operating properly, and check for clogged drippers and spray heads, and missing nozzles.

The irrigation area should be kept well vegetated, but clear of long grass and weeds. All vegetation cut in the area - such as lawn clippings - should be removed to another section of the property to make sure nutrients are not returned to the irrigation area.

Appendix 8 contains the information brochure *Your Land Application Area*. This brochure can be given to any householders who need introductory information on land application areas.

### 5.4.3 SOIL ABSORPTION

These guidelines cover some aspects of the design of soil absorption systems in order to highlight the problems associated with these systems, and to recommend a conservative design approach if a soil absorption system is being considered.

Traditionally, soil absorption systems have been used as subsurface disposal systems for wastewater from septic tanks. The design of a soil absorption system is based on the relationship between the permeability of a soil and the long-term ability of the soil to accept and transmit the treated wastewater through the soil profile, not on use of the applied nutrient and hydraulic load. In these systems, treated wastewater is generally applied at a hydraulic loading rate exceeding that which may be used by evapotranspiration, and usually at a depth where the effects of vegetation nutrient uptake and evapotranspiration are minimal.

The wastewater flows through the soil profile, eventually reaching groundwaters and surface waters. This can result in adverse public health and environmental effects. **Soil absorption systems generally do not comply with the performance objectives of these guidelines.** They could, however, be appropriate in some circumstances, depending on the site factors (particularly soil type, groundwater depth and development density).

If a soil absorption system is contemplated, consider using filter beds or amended soil systems to reduce the nutrient loading. For information on these ancillary systems see 'On-site Sewage Management Facilities' earlier in this section. Note that ancillary systems are not considered to be treatment systems that need to be certified by NSW Health. At this stage these systems are considered optional, but they might be worthy of consideration by councils, depending on the local assessment of any sensitive areas.

#### Design

There has been much debate on the long-term hydraulic loading that a soil will accept, retain and transmit. This debate has spawned various guidelines, both in Australia and overseas, specifying differing sizing criteria for soil absorption systems.

The debate has centred on the lack of correlation between the clean water percolation test and the long-term wastewater acceptance rate of the soil. This discrepancy occurs because a clogging layer can develop, affecting the soil's permeability. The clogging layer is a layer of solids (including bacteria and metal sulphides) formed after a few months of applying wastewater to land.

Resting soil absorption systems by using dual land application areas allows the clogging layer to dry, become aerobic and thin out. Application areas can be rotated every three to six months. The resting area can also serve as an emergency unit, or for use during wet weather. Alternating areas is a particularly effective strategy for slightly clayey soils. **A conservative approach should be taken if a soil absorption system is being considered.**

A hydraulic loading rate of 2 - 5 mm per day over the bottom area should be used if a soil absorption system is to be used. The site and soil features listed in Section 4 should be

studied to see if the area is suitable for an absorption system. The system should be designed so that it makes the best possible use of evapotranspiration.

### Installation

Absorption areas should be located in accordance with the results of the site evaluation, and landscaped and sloped to avoid run-off and ponding of effluent. A dedicated area that receives all the treated wastewater should be formed. The system must distribute wastewater evenly over the area, so underground pipes or trenches should be installed parallel to the contour.

Soil compaction and shearing of soil structure should be minimised during the installation. If soil structure is altered during construction, the system will have to be redesigned to account for the changes.

Detailed installation requirements can be found in AS 1547.

### Operation and Maintenance

Treated wastewater should not be applied to land if site conditions (weather, soil moisture) are such that surface ponding or run-off of treated wastewater might occur. Do not extract groundwater for potable use from areas near absorption systems (for example, by spearpoint).

The householder should inspect the system regularly to make sure it is working properly, and a service agent should do an annual inspection. Visible signs of system failure include:

- surface ponding and run-off of treated wastewater
- degradation of soil structure (for example, sheet and rill erosion, surface crusts, hard surfaces)
- poor vegetation growth
- unusual odours.

As the effluent is applied below the ground and contamination of the groundwater might not be evident, local councils could require periodic analysis of soil or groundwater characteristics - for example, measurement of the phosphorus adsorption capacity - to check the performance of the system.

The brochure *Your Land Application Area* in Appendix 8 gives householders introductory information on land application areas.

## 5.5 PARTIAL ON-SITE SEWAGE MANAGEMENT

Partial on-site sewage management typically involves the transfer of partly treated sewage to a centralised sewage management facility. This transfer is via a sanitary drainage system (in the case of a common effluent system), or by road transport (in the case of a pump-out system or chemical toilet).

### 5.5.1 COMMON EFFLUENT SYSTEMS (CES)

A common effluent system (CES) removes the need for on-site land application. It typically requires preliminary sewage treatment to be done on-site in a treatment device, such as a septic tank. This is followed by collection and transport of the wastewater (either by gravity drainage, vacuum or pumping) through small diameter pipes (because the solids load is decreased) to a centralised sewage management facility for additional management.

The householder is often responsible for the operation of the on-site component of the system, and local councils must ensure that the overall CES is managed to ensure correct operation. Failure of a single on-site sewage treatment system that is part of a CES may cause blockages in the sanitary drainage system and hence create nuisance to other users. In many circumstances it may be beneficial for the local council to take over management of both the on-site and off-site components of the system. This would mean that the council would not need to rely so much on the property owner, so it would have better control over the quality of the wastewater entering the centralised sewerage system.

In the design of a CES, the wastewater quality, quantity and flow rate characteristics must be considered. The local council must get approval from DLWC under the *Local Government Act 1993*, as well as a pollution control approval and pollution control licence from the EPA to install and operate the CES. The local council will need to show the EPA that the system is designed, and will be managed, in such a way that it meets the performance objectives of these guidelines and any other requirements for sewerage systems. The local council should make early contact with the relevant EPA and DLWC office if a CES is being considered for an area, in order to determine specific requirements.

For more information about centralised wastewater management, see the EPA's *Draft Environmental Guidelines for Industry - The Utilisation of Treated Effluent by Irrigation* (1995) and the *Environmental Management Guidelines for the Use and Disposal of Biosolids Products* (NSW Environment Protection Authority, 1997).

#### NSW Health Certification

An appropriate CES pretreatment device must be certified by NSW Health. It can take the form of a septic tank, an AWTS, a wastewater ejection unit, or some other form of device. A separate guideline is to be developed by NSW Health for certification of CES pretreatment

devices. Installation, maintenance and servicing would follow those parameters mentioned for a septic tank, AWTS or wastewater ejection device.

### Local Council Approval

Council approval is needed to install a pretreatment device. Local councils should develop a plan of management for the CES to ensure that an appropriate support infrastructure is available.

### Installation

If the pretreatment device conforms with septic tank or AWTS requirements, see the details on septic tanks and AWTS in this section for installation details.

### Operation and Maintenance

If the pretreatment device conforms with septic tank or AWTS requirements, see the information on septic tanks or AWTS in this section for operation and maintenance details.

If a pumped reticulation system is used, the power supply to the pump must not be turned off. The pumps used are usually positive displacement types and fail easily on pumping dry. Leakage of glands and seals is also common and should be repaired promptly. Where a gearbox or belt is used it should be kept in good condition.

### Advantages

- removes and treats solids separately and therefore allows savings, because there are less stringent requirements on pipe sizes and gradients for reticulation.
- a central facility allows for point source treatment and use
- cheaper than a conventional gravity sewerage scheme
- can allow sewage management to be provided to areas that currently rely on failing on-site use systems
- allows smaller lot sizes.

### Disadvantages

- the home owner can be responsible for maintenance of the pre-treatment device
- the pre-treatment device will require periodic desludging
- a septic effluent is more corrosive to the sanitary drainage system than untreated wastewater
- the central treatment facility must be designed to treat septic effluent
- greater potential for odour release from the sanitary drainage system
- higher maintenance costs than for conventional gravity systems.

## 5.5.2 CHEMICAL TOILETS

### Function

A chemical toilet receives human excreta in a holding tank for removal by a road tanker. The holding tank is charged with a deodorising chemical. There can be permanent installations, but chemical toilets have found their niche as portable toilets for outdoor concerts, agricultural shows, special events and other short-term temporary uses, and as toilets on building sites.

A chemical toilet is simply a holding chamber that contains a chemical deodoriser to mask the odour of the deposited human excreta and hand-basin wastes. The human excreta is deposited directly into the holding well, and there is no barrier between the human excreta and the user (that is, there is no flushing and trapping apparatus). Some chemical toilets have a water storage tank supplying a small hand-basin, which is operated by a small hand pump similar to those found in caravans.

The standard of traditional chemical toilets can be upgraded to improve ventilation, require flushing and improve anchorage when installed.

### NSW Health Certification

In the past, portable chemical toilets did not have to be certified by NSW Health. However, in 1998 certification will be required under guidelines that are currently being drafted.

### Local Council Approval

Local council approval is needed to install chemical toilets, and conditions might be applied, for example, on how often the waste is removed. It might be difficult to approve the installation of chemical toilets that are mounted on trailers for worker gangs; in cases like these, it would be appropriate to grant the approval to the home-base of operations, subject to maintenance and waste removal conditions.

Sewage from chemical toilets is considered to be a trade-waste and councils should not permit its discharge to sewer without the prior approval of DLWC and the local water authority.

### Installation

Chemical toilets are temporary measures for receiving human wastes, so it is not considered necessary to inspect every installation. Random inspections of installed chemical toilets should be done at building sites and at venues where many chemical toilets are used, such as circuses, concerts and shows. Chemical toilets need to be securely anchored, particularly at building sites, to stop vandals tipping them over.

### Operation

There are no special operation requirements.

## Maintenance

Maintenance is also simple. It is usually done by the hire firm, and involves pumping out the holding tank, replenishing the deodoriser and the hand-basin storage tank, and cleaning and repairing the toilet.

## Advantages

- an effective way to collect human waste from many patrons at temporary venues or construction sites

## Disadvantages

- usually poorly ventilated
- can be subject to vandalism in remote or unsecured locations
- no barrier between the human excreta and the user.

### 5.5.3 PUMP-OUT SYSTEMS

A collection well that receives effluent from a septic tank that is frequently pumped out by a road tanker is known as a 'pump-out' system. Pump-out of partly treated domestic wastewater should only be considered as a last resort, and only where on-site systems are failing and if connection to the sewer is not possible. Development relying on a pump-out system should be prohibited; it is **not a viable option in the long-term** because of widespread misuse and abuse by householders.

The collection well should be sized to contain a maximum of seven days' daily flow for a weekly pump-out. The size of the collection well is also calculated according to whether there is a standby pump available in case of main pump failure (see the section on septic tanks for sizing criteria).

The draw-off pump-out line is usually of 50 mm pipe, which should be protected from damage and which terminates at the property boundary, where a gate valve is fitted.

Local councils should consider ways of ensuring deliberate illegal discharges do not occur, by levying an annual charge or special rate regardless of pump-out frequency or quantity. The local council must have an appropriate infrastructure in place to allow for the efficient monitoring and operation of pump-out schemes. Pump-out systems constitute a high health risk if inappropriate or inferior infrastructures for system management are provided.

## NSW Health Certification

Collection wells (holding tanks) used for effluent collection must be certified by NSW Health.



## Local Council Approval

As the septic tank pump-out system stores septic tank effluent before removal, a fee for removal is charged. Experience has shown that a pump-out rate based on a flat weekly charge has led to a reduction in illegal discharges. Such a charge may disadvantage those premises of temporary occupancy such as weekenders and holiday homes, but it is offset by the reduction in the number of complaints of illegal discharges received by local councils.

Collection well sizes should be based on a maximum weekly pump-out frequency. Suggested conditions of approval are contained in Appendix 3.

Because of the potential management problems posed by pump-out systems, they should not be approved for new developments.

## Installation

When a land application system has failed there might be no other alternative than to install a pump-out system. The local council should ensure that it has an adequate infrastructure and a suitable contractor to remove septic tank effluent once a week from every premises. All collection wells should be fitted with a graduated dipstick and a lockable gate valve at the property boundary. Sufficient and appropriate access and standing area should be provided for the pump-out vehicle.

In extreme cases, and if there are adverse site contours, it might be necessary to install a collection well below the septic tank. This well pumps the effluent to another collection well near the boundary, or pumps to boost pressure to help the suction pump on the tanker. Pumps might need three-phase electrical wiring and might need a special service.

All installations should be inspected before they are commissioned, and again at frequent intervals, to ensure that illegal diversions have not occurred. All occurrences of nil pump-outs should be investigated.

## Operation

As a pump-out system is a septic tank installation, the same operating requirements apply. See the section on septic tank installations in these guidelines.

## Maintenance

Maintenance is the same as specified for septic tanks. However, as some pump-out installations require pumping facilities, maintenance of the pump is crucial to successful operation.

## Advantages

- can be used on extremely difficult sites as a last option
- relatively cheap installation unless three-phase wiring is required for pumps

## Disadvantages

- high costs of effluent pump service
- depend highly on infrastructure of tankers, management facilities and administration
- prone to abuse and widespread illegal discharge of wastewater to waterways and to public and private land by householders.

### 5.5.4 WASTEWATER EJECTION UNITS

Wastewater ejection units are considered human waste treatment devices and can be used where there is an adverse rise to an existing sanitary drainage system. This system uses a septic tank vessel that has a comminution and maceration pump installed. This kind of pump macerates all of the wastewater and solids and pumps the effluent to the sewer main.

#### NSW Health Certification

In the past, these units have not required NSW Health Certification. However, in the interests of protecting public health, it is important that reliable units are installed at appropriate locations. NSW Health is preparing guidelines for assessment and certification.

#### Local Council Approval

Local council approval is needed to install wastewater ejection units. The approval of the sewerage authority would also be required in most cases.

#### Installation

It is important to ensure that the maceration and comminution unit is activated by a float switch to allow the unit to operate without overflow. An alarm system should be activated at a high level or when the pump fails to operate.

#### Operation and Maintenance

As there is no biological process involved in the treatment of wastewater, the only important operational requirement is to stop extraneous solid objects from entering the system and damaging the pump.

Power supply to the pump must not be turned off. Pumps are usually positive displacement types and fail easily if they pump dry. Leakage of glands and seals is also common and should be repaired promptly. If a gearbox or belt is used it should be maintained in good condition.

Regular servicing of the pump at 12-monthly intervals, and periodic testing of the alarm system according to the manufacturer's instructions, are important.

## Advantages

- allows access to an existing sanitary drainage system where the building is lower than the sewer main.
- does not rely on a biological process for treatment.
- low maintenance
- less reliance on water conservation
- can handle shock loadings

## Disadvantages

- high capital cost
- may need three-phase electrical wiring.
- a sanitary drainage system must be available.

## 5.6 TOTAL OFF-SITE SEWAGE MANAGEMENT

Total off-site sewage management typically involves the transport of untreated domestic wastewater to a centralised sewage management facility, using a sanitary drainage system. The drainage system can take several forms, including conventional gravity drainage, vacuum, or pumped.

These guidelines do not give detailed information on centralised sewerage systems. For further information contact DLWC.





## **Section Six**

# **Selecting an On-site Sewage Management System**

## 6.1 INTRODUCTION

The developer or landholder can use the information generated by the site evaluation (see Section 4) to help choose the best on-site sewage management system for the site. It is important when choosing a system to ensure that the **most limiting** site and soil features are identified and used as a basis for selection.

Various combinations of on-site system processes are possible, and not all on-site sewage management processes may be suitable or desirable at all sites. For example, some local councils will not allow the use of septic tanks with absorption trenches or pump-out facilities in their areas.

A thorough knowledge of available systems is needed - including their operation and performance - to make sure that the correct system is selected for the site. (See Section 5 for information on the various wastewater treatment and land application systems and their management.)

It might be helpful to start from the site and soil constraints and work 'backwards' through the treatment train. That is:

- decide on an appropriate land application system based on site and soil features
- work out the required effluent quality, based on the site sensitivity and land application area design
- finally, choose the treatment and ancillary systems needed to achieve the effluent quality.

## 6.2 IMPORTANT CONSIDERATIONS

### 6.2.1 GENERAL

When you are selecting an on-site sewage management system, many important issues need to be considered, including:

- the sustainability of the chosen system
- the expectations of the future residents of the development and their likely commitment to proper operation and maintenance of the system
- site suitability, including environmental sensitivity
- system reliability and the quality of service offered by the manufacturer (if any)
- the availability of service agents in the area and their quality of service
- system cost

- system lifespan:
  - would on-site management be a long-term management strategy, or only an interim measure before connection to a centralised sewerage system?
  - would the chosen system need to be replaced or refurbished?
- the cumulative public health and environmental impacts of present and possible future on-site sewage management systems within the catchment
- the development of contingency plans in case of system failure
- the impact of the system on the amenity of the area.

## 6.2.2 CLIMATE

In some areas of New South Wales, heavy rainfall patterns make it difficult to apply effluent to land for some or all of the year without contaminating run-off from the site. In these cases, alternative options for on-site sewage management are needed; the initial option to consider is to provide some form of centralised sewerage system.

Other suitable options might require greater commitment by the resident, or changes to the design, such as a larger land application area. Remember that the performance objectives of the guidelines must be met, and this means containing all pollutants on-site.

Apart from sewerage the development, which has the dual benefit of allowing more appropriate management of wastewater and smaller block sizes, it may be possible to investigate the following:

- **Decrease the hydraulic and nutrient load.** The implementation of wastewater and nutrient reduction initiatives such as the use of low phosphate detergents, composting toilets, effluent recycling, and water-saving shower heads, taps and appliances, can lead to significant reductions in irrigation area and wet weather storage requirements.
- **Provide on-site wet weather storage.** If wastewater cannot be applied to land (because of the possibility of surfacing and run-off of wastewater) for a small period of time, consider putting in on-site wet weather storage. This storage must be in the form of enclosed tanks to ensure public health protection. A balance between irrigation area size and volume of storage can be achieved by considering rainfall patterns and optimum irrigation levels, although a minimum storage capacity of three days is recommended.

Also consider installing soil moisture sensors attached to automatic pumps; these ensure that treated wastewater is applied at the appropriate time and rate to prevent irrigation when the ground is saturated. If wet weather storage facilities are provided, then they must be managed properly, and this includes ensuring that the storage facility is empty when it is not being used. For wet weather storages to work well the householder needs to be committed to their management. To estimate the wet weather storage volume needed, see the water balance methods explained in Section 4 and Appendix 6.

- **Treat effluent to a higher level.** It might be possible to reduce the pollutant load transferred to the soil by treating the effluent to a higher level. Options include using recirculating sand filters, sand mounds, or amended soil structures. Wet weather storage will generally still be required. Councils may need to undertake an analysis of the risk to the environment and public health from permitting a given level of wet weather discharge in order to allow area and storage trade-offs to be made. This might require some form of catchment or LGA modelling to ensure an informed decision is reached.
- **Increase the size of the land application area.** In certain climates it might be possible to increase the size of the land application area, thus reducing the application rate and possibly reducing the wet weather storage requirement. Although some compromise may be achieved, the storage should not be reduced below a three-day minimum. Manage the irrigation area carefully so that effluent is applied evenly to minimise the likelihood of topsoil erosion and effluent run-off.
- **Investigate other technologies and management practices.** These should focus on containing all pollutants within the boundary of the premises without disposal to groundwater. It may be necessary to find new ways to apply systems or processes such as sealed evapotranspiration mounds, waterless composting toilets, effluent recycling systems, advanced instrumentation, and process control, to suit special circumstances.
- **Investigate partial on-site sewage management systems.** Instead of providing a large wet weather storage, a small storage might be sufficient for the drier periods of the year, with a pump-out and treatment at a central location provided for excess effluent in the wetter periods when irrigation cannot be used. This will need to be done with the cooperation of the local sewerage operating authorities.

### 6.2.3 WASTE STREAMS

When you are selecting an on-site sewage management system it is important to be aware of the individual waste streams that make up the total waste stream. These individual streams are often described as blackwater (flushing toilet waste and human excreta) and greywater (kitchen, bathroom and laundry wastes). Each of these can be managed separately or together when you are choosing the components of a treatment system. If you are considering separate systems, it is important to ensure that **both** streams are managed to conform with the performance objectives of these guidelines (for example, if a composting toilet is to be installed, then you must plan to manage the greywater separately).





#### 6.2.4 SYSTEM COMBINATIONS

Different combinations of treatment and land application systems can be used for the **same** waste stream. Not all unit processes are compatible (for example, chlorinating septic tank effluent is not an efficient process because of its high suspended solids content). A competent professional should investigate the integration and compatibility of systems. With all system combinations, the waste stream should be managed to conform to the performance objectives of these guidelines.

Table 16 shows typical combinations of treatment and application systems. This should help in the selection of an appropriate sewage management system.

**Table 16: On-site Sewage Management System Combinations**

Effluent Management System	Human Waste Treatment Device	Possible Waste Stream(s)	Also requires	Optional Processes in Sensitive Areas
Subsurface irrigation	AWTS	Total Wastewater	Septage removal Wet weather management protocol	Disinfection Constructed wetland
	Septic Tank	Total Wastewater or greywater or blackwater	(a) recirculating sand filter or (b) amended soil system or (c) sand mound Septage removal Wet weather management protocol	Disinfection Constructed wetland
	Wet composting toilet	Total Wastewater and food wastes	(a) recirculating sand filter or (b) amended soil system or (c) sand mound Compost burial on-site Wet weather management protocol	Disinfection Constructed wetland
	Waterless composting toilet	Human excreta and food wastes	Compost burial on-site Excess liquid should be managed as per total wastewater stream	
	Greywater treatment device	Greywater	Septage removal Wet weather management protocol	Disinfection Constructed wetland
Surface spray, trickle and drip irrigation	AWTS	Total Wastewater	Disinfection Septage removal Wet weather management protocol	Constructed wetland
	Greywater treatment device	Greywater	Disinfection Septage removal Wet weather management protocol	Constructed wetland
Soil absorption  (conservative design approach must be adopted)	AWTS	Total Wastewater	Septage removal	Disinfection and Constructed wetland
	Septic Tank	Total Wastewater or greywater or blackwater	Septage removal	Disinfection Constructed wetland Recirculating sand filter Amended soil system Sand Mound
	Wet composting toilet	Total Wastewater and food wastes	Compost burial on-site	Disinfection Constructed wetland Recirculating sand filter Amended soil system Sand Mound
	Waterless composting toilet	Human excreta and food wastes	Compost burial on-site Excess liquid should be managed as per total wastewater stream	
	Greywater Tank	Greywater	Septage removal	Disinfection Constructed wetland
Pump-out system or common effluent system (pump-out systems are not usually viable in the long-term)	AWTS	Total Wastewater	Septage removal Effluent storage (for pump-out)	
	Wet composting toilet	Total Wastewater and food wastes	Compost burial on-site Septage removal Effluent storage (for pump-out)	
	Septic Tank	Total Wastewater or greywater or blackwater	Septage removal Effluent storage (for pump-out)	
	Waterless composting toilet	Human excreta and food wastes	Compost burial on-site Excess liquid should be managed as per total wastewater stream	
	CES pre-treatment device	Total wastewater	Septage removal	
	Greywater Tank	Greywater	Septage removal Effluent storage (for pump-out)	





# **Appendices and Further Information**

# APPENDIX 1

## ON-SITE SEWAGE MANAGEMENT STRATEGY CHECKLIST

The following is a checklist of matters to consider in preparing local area on-site sewage management plans, development control plans, local policies and guidelines for on-site sewage management. Specific provision should be made in the council's On-site Sewage Management Strategy for the development of statutory plans and regulatory policies for sewage management in particular areas.

### ON-SITE SEWAGE MANAGEMENT PLANS

On-site sewage management plans can be prepared for individual sites, for subdivision release areas, particular localities, sub-catchments or any other area where a specific plan will help on-site sewage management objectives. Items to be considered include:

#### Local Area Description

Include maps, photos, or descriptions of:

- location
- size
- boundaries
- facilities (including water supply and sewerage infrastructure in the area)
- relationship to adjoining areas

#### Nature and Extent of Environmentally Sensitive Areas

Establish the extent and nature of any environmentally sensitive areas in the study area, in adjoining areas, or within the downstream catchment. These might include:

- potable aquifers
- areas with vulnerable groundwater
- drinking water catchments
- wetlands, sand dunes, alluvial flats, sensitive vegetation.

#### System Failure

Assess the impact of system failure and adopt appropriate risk management strategies. Assess the likely fate of pollutants released during a system failure and the potential impacts of such pollutants on adjoining sites and other areas and within the downstream catchment.

### **Sewage Management Options**

Consider the full range of sewage management options based on health and environmental objectives (including cumulative impacts), resource management issues and social and economic factors. If cost-benefit analysis is to be used, then estimates of the economic value of the environment should be developed. Under the Country Towns Water, Sewerage and Drainage Program, DLWC may also provide technical, management and financial support to local councils in country NSW (DLWC 1996).

### **Water Conservation**

Water conservation is a factor in all aspects of on-site sewage management. Householders should be aware of water cycle management principles and encouraged to limit water use, to provide stormwater storage facilities, to re-use treated wastewater on site and to select and manage vegetation to encourage efficient evapotranspiration processes.

## **DEVELOPMENT REQUIREMENTS & REGULATORY CONTROLS**

Development requirements for subdivision and other development involving on-site sewage management, as well as performance standards for on-site sewage management systems, should be specified or called up in DCPs and local policies. The following items should be considered:

### **Environmentally Sensitive Areas**

Specifically consider the management of environmentally sensitive areas. For example:

- restricting the application of effluent over aquifers providing potable water supply
- creating public reserves on waterfrontages to maintain a riparian buffer
- requiring extended buffers between on-site sewage management systems and sensitive waterways and vegetation
- restricting the removal of vegetation.

### **Water-efficient Devices**

It is appropriate to require water use reduction devices to be installed in all domestic premises, but this is especially desirable when on-site sewage management is involved. Additional water consuming devices such as spas and pools will increase total water inputs for on-site sewage management and should be discouraged, unless specifically included in design calculations for the on-site sewage management system. In-sink food disposal units should not be coupled to domestic on-site sewage management systems.

### **Stormwater Management**

Effective on-site sewage management involves consideration of the total water cycle for the site or planning area. Pay particular attention to the management of stormwater, including encouraging the use of rainwater storage tanks, the need to divert stormwater from effluent

application areas and the desirability of providing stormwater detention and percolation facilities.

### **On-site Sewage Management Systems**

The council might wish to recommend the use of specific types of on-site sewage management systems in a particular area. Consider the full range of available treatment devices and land application systems for treated effluent.

It might be helpful to provide area-specific guidelines, showing how developers or householders can select an on-site sewage management system based on site, soil and climate assessments, household requirements and council recommendations.

### **Wet Weather Storage**

Council might wish to stipulate a certain wet weather storage requirement, or suggest a method by which wet weather storage can be calculated. See the discussion of wet weather storage issues in Section 4 and Appendix 6 of these guidelines.

### **Minimum Effluent Application Areas**

A minimum area requirement for on-site effluent application may be specified for residential subdivision in non-sewered areas. If this varies over a study area, then descriptions or maps may be included. A minimum effluent application area can be calculated using the techniques described in these guidelines. The area will vary depending on site and soil conditions, climate, the type of available water supply (rainwater tanks, borewater or reticulated water service) and the type of treatment system and effluent application system selected. The minimum effluent application area should include a sufficient reserve to allow rotation of the dosing area to help recovery of soils and vegetation and to provide an alternative application area in case of system failure.

There is an emerging community demand for the installation of household greywater recycling systems in sewerred areas, and consideration should also be given to minimum areas for greywater recycling.

### **Buffer Distances**

Specify secure buffer distances, including distances from waterways, site boundaries, pathways, other buildings and utility areas on the site.

### **Estimation of Wastewater Generation**

Specify a standard method for calculating the volume of wastewater generated by a household or development. This might consider issues like available water supply, water-using facilities and devices to be installed, and accommodation potential.

### **Sizing of Treatment Systems**

Consider the recommendations set out in these guidelines and in other relevant standards, as well as manufacturers' recommendations, when determining the sizing requirements for on-site sewage treatment systems.

### **Installation of On-site Sewage Management Systems**

General requirements for installing an on-site sewage management system should be specified, including:

- materials, methods and techniques of installation and construction site management issues (including actions to be avoided, such as smearing clays in soil absorption systems or driving heavy vehicles on the effluent application area)
- landscaping and surface water diversion requirements
- council accreditation of qualified installers
- construction monitoring and inspection requirements
- commissioning procedures
- access for operation and maintenance.

### **Information to be Supplied by Developers**

Specify information requirements for site, soil and climatic assessments, together with evaluation methods and capability ratings. Developers should be required to outline the methodology and reasoning behind the selection of a particular on-site sewage management system. They should give an explanation of how the system will conform to the performance objectives of these guidelines.

### **Performance Standards for Existing Systems**

Performance standards based on the environment and health protection objectives of these guidelines should be specified in local approval and order policies in relation to all existing wastewater management systems. Controls must cover the discharge of contaminated material across property boundaries, and the surface ponding of effluent.

### **Failing Systems Within Existing Developments**

Consider options for upgrading failing systems and address them in guidelines to property owners. Longer-term solutions, such as common effluent management and sewerage services, should be considered if there are continuing concerns over environment and health risks.

### **New Construction Within Previously Subdivided Areas**

Development requirements and performance standards should be developed for new constructions in previously subdivided areas. On-site sewage management systems designed for new construction should meet the performance objectives of these guidelines. This could require the use of innovative or more costly technologies and system management



regimes, particularly where the site characteristics are more constraining.

### **Water Supply**

Before providing reticulated water supply to premises using on-site sewage treatment systems, re-assess the capacity of existing treatment systems and land application areas to accommodate increased flow rates. Upgrade systems to ensure that performance standards continue to be met.

### **Connection to Sewer**

The local council can require premises in sewerred areas to be connected to the sewer. The council might wish to prepare a local orders policy (LOP) setting out matters to be considered before requiring premises to connect to the sewer.

Consider the availability of sewerage services when rural residential release strategies are being developed. Issues to be addressed include proximity to sewerred areas, the density of the development, the site and soil characteristics and the long-term cost comparison of on-site and reticulated sewage management options.

## APPENDIX 2

### MODEL SITE REPORT

<b>1 SITE EVALUATORS</b>	
Company	Name(s)
Address	
ph:	fax:
Date of assessment:     /     /	Signature of evaluator:                     /     /

<b>2 SITE INFORMATION</b>	
Address/locality of site	Council area
Owner/developer:	ph:
Address:	
Size/shape/layout Site plans attached Photograph attached	yes/no
Intended water supply	rainwater reticulated water supply bore/groundwater
Expected wastewater quantity (litres/day)	
Local experience (information attached regarding on-site sewage management systems installed in the locality)	yes/no

If any site or soil features have not been assessed, note why.

<b>3</b>	<b>SITE ASSESSMENT</b>
Climate	
Are low temperatures expected (particularly below 15°C)? yes/no	
Where appropriate:	
Rainfall water balance attached	yes/no
Land application area calculation attached	yes/no
Wet weather storage area calculation attached	yes/no
Flood potential	
Land application area above 1 in 20 year flood level	yes/no
Land application area above 1 in 100 year flood level	yes/no
Electrical components above 1 in 100 year flood level	yes/no
Exposure	
Slope	
Landform	
Run-on and seepage	
Erosion potential	
Site drainage	
Fill	
Groundwater	
Horizontal distance to groundwater well used for domestic water supply (m)	
Relevant groundwater vulnerability map referred to?	yes/no/not available
Level of protection (I – VI)	
Bores in the area and their purpose:	
Buffer distances from wastewater	
Management system to:	
Permanent waters (m)	
Other waters (m)	
Other sensitive environments (m)	
Boundary of premises (m)	
Swimming pools (m)	
Buildings (m)	
Is there sufficient land area available for:	
Application system (including buffer distances)	yes/no
Reserve application system (including buffer distances)	yes/no
Surface rocks	

<b>4 SOIL ASSESSMENT</b>
Depth to bedrock or hardpan (m)
Depth to high soil watertable (m)
Hydraulic loading rate (where applicable) Soil structure: Soil texture: Permeability category: Other measures of soil permeability: Hydraulic loading recommended for soil absorption system (mm/day): Reasons for the hydraulic loading recommendation:
Coarse fragments (%)
Bulk density (and texture) (g/cm <sup>3</sup> )
pH
Electrical conductivity (dS/m)
Exchangeable sodium percentage
Cation exchange capacity (cmol <sup>+</sup> /kg)
Phosphorus sorption index
Geology & soil landscape survey Presence of discontinuities Presence of fractured subsoil Soil and Landscape map reference:
Dispersiveness



## APPENDIX 3

### MODEL SEPTIC TANK AND PUMP-OUT CONDITIONS OF APPROVAL

Date: \_\_\_\_\_

#### A GENERAL CONDITIONS

- 1 All sanitary plumbing and drainage work is done in accordance with the requirements of the local sewerage authority or the Local Government (Water, Sewerage and Drainage) Regulation 1993. No alterations or additions are permitted without the express approval of council
- 2 The installation incorporates a \_\_\_\_\_ flushing suite.
- 3 The installation incorporates a 3/6 litre dual flush cistern.
- 4 Manually operated cisterns are installed.
- 5 The maximum vertical drop in the soil line from the pan is 2.25 metres.
- 6 Flushing cisterns fitted with internal overflows must not be connected to any WC pan.
- 7 The horizontal length of pipe between the outlet of the pan and the inlet to the septic tank is no more than 3metres.
- 8 The horizontal length of pipe between the outlet of the pan and the junction with another waste to the main drain line is no more than 3 metres.
- 9 The elevated pipe line is adequately supported.
- 10 The septic tank is elevated as high as the minimum fall of the pipe line from trap pan to the septic tank, will permit, and the elevated pipes are adequately supported.
- 11 The septic tank is located not less than 1.5m from any building and access for desludging is adequate.
- 12 The \_\_\_\_\_ wastes are treated in the septic tank.
- 13 The \_\_\_\_\_ wastes are discharged to a \_\_\_\_\_.
- 14 The capacities of the septic tank / collection well (1) / collection well (2) are \_\_\_\_\_ litres and \_\_\_\_\_ litres respectively.
- 15 An automatically operated pump is provided to operate when the collection well contains \_\_\_\_\_ litres.
- 16 Liquid trade wastes, generated on the premises, must not to be discharged into the septic tank or collection well.
- 17 The contents of the existing \_\_\_\_\_ are removed to the sanitary depot in an approved vehicle and the disconnected \_\_\_\_\_ is either demolished or filled with clean soil and garden lime.
- 18 The allotments on which the building, the septic tank, and the effluent drains are situated are maintained in one ownership and are not separately disposed of while the septic tank is in use.
- 19 An adequate water supply is available at all seasons of the year.
- 20 An additional \_\_\_\_\_ litre elevated water storage tank is provided for flushing purposes.

#### B ON-SITE MANAGEMENT

- 21 The septic tank is elevated so that the effluent can be discharged into a soil absorption system in the approximate position indicated on the plan.

- 22 The septic tank and soil absorption system are constructed in the approximate positions indicated, with the trenches parallel to the contour.
- 23 All sillage not treated in the septic tank or directed to the collection well must be managed in a way that does not create any nuisance or pollute any water course.
- 24 The \_\_\_\_\_ is or are constructed in the approximate position indicated on the plan in red ink.
- 25 The soil absorption system is constructed parallel with the contour of the land in the approximate position indicated on the plan in red ink.
- 26 The land application area is retained and filled with absorbent soil as indicated on the plan. This work is to be done to the satisfaction of Council.
- 27 The land application area is terraced and filled with absorbent soil as indicated on the plan. This work is to be done to the satisfaction of Council.
- 28 An impervious retaining wall is erected in the approximate position shown on plan and the area filled with absorbent soil to Council's satisfaction.
- 29 The land application area is prepared by covering with at least \_\_\_\_\_ mm of absorbent soil and ripped into the existing top soil.
- 30 Transpiration beds are constructed to the requirements of Council and/or AS 1547, in the approximate position shown on plan.
- 31 The depressions in the land application area are filled with absorbent soil and the site graded to an even grade.
- 32 The septic tank and the land application area must be protected from possible vehicle damage. This work must be done to the satisfaction of Council.
- 33 All stormwater and seepage from higher levels is diverted from the land application area by a \_\_\_\_\_ drain.
- 34 The site has been inspected and council considers that effluent and sillage can be completely managed on the site without nuisance or likely danger to health.
- 35 The prepared land application area must be graded to a minimum of 1% cross fall on completion, and provided with turf or grass before the premises are occupied.
- 36 No water supply or any source of water supply used for drinking or domestic purposes or for stock is likely to be polluted or rendered unwholesome by the land application of effluent from the proposed septic tank.
- 37 The land application area is sited so as not to contaminate the natural watercourse that traverses the property.

### **C TANKER (PUMP-OUT)**

- 38 The site has been inspected and is suitable for the collection of effluent by the removal vehicle.
- 39 The collection well is emptied at least \_\_\_\_\_ and the contents removed in an approved vehicle to the sanitary depot for management.
- 40 The suction line is to be fitted with a gate valve and approved locking device at the \_\_\_\_\_ boundary.
- 41 A graduated dipstick of copper material not less than 13 mm in diameter is provided to the collection well. The highest graduation must indicate when the collection well is full.

### **D PUMP TO SEWER**

- 42 The conditions stipulated by the \_\_\_\_\_ in its letter of \_\_\_\_\_ are complied with.

**NOTE:** Other conditions that may apply to the particular application being recommended for approval may be either written on the 'conditions of approval' sheet or attached as a separate sheet.

## APPENDIX 4

### MODEL AWTS CONDITIONS OF APPROVAL

Date: \_\_\_\_\_

- 1 All sanitary plumbing and drainage work is done in accordance with the requirements of the local sewerage authority or the Local Government (Water, Sewerage and Drainage) Regulation 1993. No alterations or additions are permitted without the express approval of council
- 2 All effluent arising from an AWTS must be managed wholly within the premises where the system is installed.
- 3 Effluent from an AWTS must not be permitted to discharge into any natural waterway or stormwater drain.
- 4 An AWTS must not be installed in such a way that it can contaminate any domestic water supply.
- 5 All distribution lines of the irrigation system must be buried to a minimum depth of 100 mm below finished ground level.
- 6 All irrigation equipment must be installed in such a way that it will not be readily subject to damage.
- 7 All irrigation pipework and fittings must comply with AS 2698 *Plastic pipes and fittings for irrigation and rural applications*, and
  - 7.1 standard household hose fittings may not be used
  - 7.2 the irrigation system may not be capable of being connected to the mains water supply.
- 8 Effluent from AWTS must be managed by the use of one or more of the irrigation techniques specified in AS/NZS 1547
- 9 If land application is by spray irrigation, the land application area should not be used for passive or active recreational purposes.
- 10 The land application area must not be used to grow vegetables or fruit for human consumption.
- 11 The land application area may be divided into two or more areas.
- 12 Additional land application areas may be used only with the written prior approval of the local council.
- 13 Soaker hoses and standard household sprinklers and attachments must not be used for the irrigation of AWTS effluent.
- 14 The irrigation system must be operated in such a way as to prevent any run-off of effluent from the land application area.
- 15 The land application area should be landscaped by terracing and filling or retaining and filling so as to provide a relatively level area to the satisfaction of the local council.
- 16 All effluent land application areas must to be completely prepared or landscaped to the satisfaction of the local council before:
  - 16.1 in the case of a new dwelling, occupation of the dwelling
  - 16.2 in any case, commissioning of the AWTS.
- 17 Within the effluent irrigation area there must be at least two warning signs that comply with AS 1319 and have:
  - a green background
  - 20 mm high capital lettering in black or white, and
  - the words 'RECLAIMED EFFLUENT - NOT FOR DRINKING - AVOID CONTACT'.
- 18 The AWTS unit shall be maintained by a service agent approved by the local council



## APPENDIX 5

### MODEL COMPOSTING TOILET CONDITIONS OF APPROVAL

Date: \_\_\_\_\_

- 1 The humus closet must be installed and operated in accordance with the manufacturer's instructions and any conditions imposed by this approval.
- 2 There may be no more than \_\_\_\_\_ residents in the premises where the humus closet is installed.
- 3 Because the humus closet is to be installed internally within the dwelling, a separate closet room must have an external wall; access must be through a door in the external wall or through an internal wall that opens directly into a passageway that opens directly to the outside. Access may not be through a habitable room, food storage or food preparation room.
- 4 If the installation is to be external to the dwelling, the humus closet must be installed within a building in accordance with the constructional requirements provided in the *Local Government Act 1993*.
- 5 A permanent notice with basic instructions must be affixed to the unit in a prominent position. The permanent notice must include provision for recording the date of last deposit into each chamber and the last time humus material was removed.
- 6 The fan fitted to the air vent must be installed in such a way that it operates continuously. Easy access must be provided for repairs or replacement of the fan.
- 7 The minimum composting period for the \_\_\_\_\_ humus closet must be not less than \_\_\_\_\_ months.
- 8 Composted humus may be removed from the humus closet by the occupier or an authorised service agent, only after the minimum composting period as stated. The owner should ensure a working environment which meets OH&S requirements.
- 9 Humus material that has been only partly composted may be removed from the humus closet only with the written consent of the local council.
- 10 Composted humus may be removed only through the access door (where provided) or from the humus storage tray.
- 11 Composted humus may be managed only within the boundaries of the premises and by the occupier of the premises.
- 12 Composted humus may not be removed from the premises unless the written approval of the local council has been obtained.
- 13 The composted humus from the humus closet may not be disposed of directly in an area used for the production of root crops for human consumption.
- 14 The composted humus may be buried under clean friable soil in a level area not subject to erosion at a depth of 75 mm below finished ground level for a minimum period of three months.
- 15 The composted humus may be used only in an area used for the production of root crops for human consumption where:
  - 15.1 the composted humus is removed from the humus closet as specified in 10, is placed into a separate lidded compost bin providing aeration, and a period of three months elapses without further addition to or removal from the bin, or
  - 15.2 the humus so managed under 14 has seasoned for a period of not less than three months and may be recovered and used.
- 16 All sullage must be managed in a way that does not create any nuisance or pollute any watercourse.
- 17 The site has been inspected and Council considers the humus and sullage can be completely managed without nuisance or likely danger to health.

## APPENDIX 6

### ESTIMATING IRRIGATION AREA SIZE AND WET WEATHER STORAGE REQUIREMENTS

#### INTRODUCTION

Estimating the irrigation area and wet weather storage requirements is a very important aspect of on-site sewage management system design. The complex interactions between the soil, climate, topography and wastewater inputs such as hydraulic and nutrient loadings mean that there is no 'correct' method or 'right' answers. The methods shown below are considered appropriate because of their relative simplicity, and because they provide estimates consistent with more complex models and with the performance objectives of these guidelines.

Remember that all water balance calculations are simply estimates. They are not exact replications of what actually happens on an irrigation site. Small variations in the inputs to the water balance can lead to large differences in estimated irrigation area and wet weather storage requirements. To make sure that the performance objectives of these guidelines will be met, take a conservative approach when determining water balances.

This example illustrates the design of a land application area intended for a single household in a medium rainfall area. The house will have three bedrooms and is expected to accommodate five people and to generate 1000 litres of wastewater a day. The house is part of a subdivision on land identified as suitable by council for development using on-site sewage management, with the use of AWTS and subsurface irrigation being the preferred management method.

The site evaluation was done by suitably qualified people. It showed that sections of the site were suitable for land application of wastewater in terms of site and soil characteristics - that is, the site and soil showed no limiting features as listed in Tables 4, 5, 6, and 8.

#### CALCULATING THE IRRIGATION AREA AND WET WEATHER STORAGE

The irrigation area required will be estimated from either the hydraulic or the nutrient loading rate of the wastewater, depending on which is the most limiting. Both methods should be used to estimate an area, and the larger of the two chosen as the minimum irrigation area.

Remember that in some cases the irrigation area can be increased to reduce the requirement for wet weather storage (although a minimum of three days' storage is recommended).

#### NUTRIENT AND ORGANIC MATTER BALANCE

The nutrient balance should be done before the hydraulic balance, as the calculations are less difficult and also present a good initial estimate of area requirements; this tends to simplify the water balance calculations.

The formula used to determine area requirements based on organic matter and nutrient loads is as follows:

$$A = \frac{C \times Q}{L_x}$$

Where	A	=	land area (m <sup>2</sup> )
	C	=	concentration of nutrient or BOD (mg/L)
	Q	=	treated wastewater flow rate (L/d)
	L <sub>x</sub>	=	critical loading rate of nutrient or BOD (mg/m <sup>2</sup> /d)

The concentrations (C) of the nutrients or BOD expected in water treated in an AWTS are listed in Table 14. The critical loading rates for nitrogen (L<sub>n</sub>) and phosphorus (L<sub>p</sub>) are based on the ability of vegetation to use these nutrients before they pass through the root zone. For example, the L<sub>n</sub> for perennial pasture varies between 18 and 36 mg/m<sup>2</sup>/day, while L<sub>p</sub> varies between 2 and 4 mg/m<sup>2</sup>/day.

The critical loading rate for organic matter (L<sub>o</sub>) of 3000 mg/m<sup>2</sup>/day generally means that required land areas based on organic matter loading will not be limiting.

## NITROGEN LOADING

Based on a total nitrogen (TN) concentration of 37 mg/L\* in the treated wastewater and a critical TN loading rate (L<sub>n</sub>) of 25 mg/m<sup>2</sup>/d\* the area required based on TN is:

$$A = \frac{37 \times 1000}{25}$$

$$= 1480 \text{ m}^2$$

\*Note that these are nominal values. Where possible, values specific to the site and the proposed treatment system should be used.

## PHOSPHORUS LOADING

Plant uptake of phosphorus, unlike nitrogen, is a minor mechanism of removal. The major mechanism for phosphorus removal is soil adsorption. This is not renewable. As stated in Table 6, soils with a phosphorus sorption capacity of over 6000 kilograms per hectare (calculated to a depth of 1 metre) should not be limiting for irrigation areas. Phosphorus sorption by the soil is expected to occur up to about a quarter to half of the phosphorus sorption capacity (an average value of one third will be used for this example). Beyond this, leaching of phosphorus can occur if the phosphorus is not used by vegetation uptake. A soil with a phosphorus sorption ability of at least 50 years (in terms of µg P/g soil), based on the expected phosphorus load, is recommended for land application areas.

Based on a total phosphorus (TP) concentration of 12 mg/L\* in the treated wastewater, a critical loading rate ( $L_p$ ) of 3 mg/m<sup>2</sup>/day\*, and a phosphorus sorption capacity of 6000 kilograms per hectare\* the determination of irrigation area is as follows:

Determine the amount of phosphorus that can be adsorbed without leaching over 50 years

$$\begin{aligned} P_{\text{adsorbed}} &= 6000 \times 1/3 \\ &= 2000 \text{ kg/ha} \\ &= 0.2 \text{ kg/m}^2 \end{aligned}$$

Determine the amount of vegetation uptake over 50 years

$$\begin{aligned} P_{\text{uptake}} &= 3 \times 365 \times 50 \\ &= 54\,750 \text{ mg/m}^2 \\ &= 0.055 \text{ kg/m}^2 \end{aligned}$$

Determine the amount of phosphorus generated over that time

$$\begin{aligned} P_{\text{generated}} &= \text{total phosphorus (TP) concentration} \times \text{volume of} \\ &\quad \text{wastewater produced in 50 years} \\ &= 12 \times 1000 \times 365 \times 50 \\ &= 219 \times 10^6 \text{ mg} \\ &= 219 \text{ kg} \end{aligned}$$

\*Note that these are nominal values. Where possible, values specific to the site and the proposed treatment system should be used.

Determine the irrigation area required:

$$\begin{aligned} \text{Irrigation area} &= P_{\text{generated}} / (P_{\text{adsorbed}} + P_{\text{uptake}}) \\ &= 219 / (0.2 + 0.055) \\ &= \mathbf{860 \text{ m}^2} \end{aligned}$$

Nitrogen is therefore the limiting nutrient, as its area requirement of 1480m<sup>2</sup> is the larger of the two.

## HYDRAULIC LOADING

The irrigation of treated wastewater is based on the complete re-use of the hydraulic component of the wastewater. In order to determine an effective size for an irrigation area and wet weather storage facility, the hydraulic inputs and outputs must be balanced to ensure there are no losses from the system other than those intended (that is, evapotranspiration and some percolation).

There are essentially two ways to estimate irrigation area and wet weather storage requirements. The first method entails the nomination of an irrigation area size and then estimation of the wet weather storage requirement via a water balance. The second method uses a water balance model to estimate a *minimum* irrigation area requirement (it should be noted that this also means that the wet weather storage is a maximum). These two methods are explained below with an example.

## NOMINATED AREA METHOD

The nominated area method is usually the simplest, as an initial irrigation area size can be nominated from the nutrient balances for phosphorus and nitrogen.

Table A6.1 contains a water balance calculation for determining the wet weather storage requirement based on a nominated irrigation area of 1480 m<sup>2</sup>, the largest area estimated above from the nutrient loadings.

A water balance is based on the following equation calculated on a monthly basis:

$$\begin{array}{l} \textit{Design} \\ \textit{Precipitation} \end{array} + \begin{array}{l} \textit{Wastewater} \\ \textit{Applied} \end{array} = \textit{Evapotranspiration} + \textit{Percolation}$$

$$\text{Or } P + W = E T + B$$

This relationship may be thought of as 'input equals output'. A water balance is simply the determination of this equation for each month of the year. June will be used as the example month in the text, but all data may be found in Table A6.1.

### Inputs

- Precipitation (P) - The 50th percentile monthly precipitation is entered into the water balance. Historical data were obtained from the Bureau of Meteorology; for June the design precipitation is 67 mm.
- Wastewater applied (W) - The theoretical effluent irrigation depth needs to be calculated from the design wastewater production and the nominated irrigation area. This involves determining how much effluent is generated in a month ( $Q \times D$ ), and dividing this by the irrigation area (note that the application of one litre per metre squared is equivalent to an irrigation depth of 1 millimetre). For June this is:

$$W = (1000 \times 30) / 1480 = 20.3 \text{ mm/month}$$

The input is simply the sum of these two parameters for each month. That is:

$$\text{Input} = 67 + 20.3 = 87.3 \text{ mm}$$

## Outputs

- Evapotranspiration (ET) - Monthly evapotranspiration is estimated to be a certain percentage of the monthly evaporation. This percentage is known as the 'crop factor'. The crop factor can vary, depending on the type of plant being grown, the area of the state where the irrigation area is placed, the time of the year, and exposure of the site. For lawn and turf, the crop factor varies between about 0.6 and 0.8, for shrubs the value is about 0.5, and for forests it is about 1.0. An average value of 0.7 will be used for this example. Take a conservative approach when choosing a crop factor unless studies show otherwise. For further information contact the Organic Waste Recycling Unit of NSW Agriculture. Historical monthly evaporation data is obtained from the Bureau of Meteorology. For June the determination of ET is as follows:

$$ET = 87 \times 0.7 = 60.9 \text{ mm/month}$$

- Percolation (B) - A nominal weekly percolation rate of 5 mm is entered into the water balance to allow for leaching of salts out of the root zone. This is converted to a monthly rate by dividing by seven (to get daily percolation) and multiplying by the number of days in each month to get a monthly value. For June this is as follows:

$$B = (5 / 7) \times 30 = 21.4 \text{ mm/month}$$

The output is simply the sum of these two parameters for each month. That is:

$$\text{Output} = 60.9 + 21.4 = 82.3 \text{ mm/month}$$

## Wet Weather Storage Requirements

The wet weather storage estimation is based on the water balance 'input equals output'. However, problems are encountered when the input exceeds the output, and is normally demonstrated when systems are overloaded during rainfall and effluent is exported from the site as surface run off. Storage is needed for these times, and the water balance may be rewritten as:

$$\textit{input} - \textit{output} = \textit{storage}$$

In Table A6.1 the wet weather storage determination is represented as follows:

- Storage (S) - The storage is based on the straightforward water balance calculation of 'storage equals input minus output'. For June this is:

$$S = 87.3 - 82.3 = 5.0 \text{ mm}$$

Note: using this theoretical water balance method, the storage can sometimes 'include' some of the rainfall portion of the water balance, depending on the climate. The actual storage should be limited to storing only the wastewater portion of the inputs (that is, if a month appears to have a storage greater than the amount of wastewater generated during that month, then the actual storage should only consider the wastewater portion, or S equals W).

- Cumulative Storage (M) - Cumulative storage needs to be determined when more than a single consecutive month requires storage. The first positive 'S' value in the year should be identified by looking along the 'S' row from left to right (in this case it is 5.0 mm for June). This value is set as the 'M' value for that month. The 'M' value for the next month (in this case July) is determined by adding the 'S' value for July to the 'M' value for the previous month. That is:

$$M_{Jul} = 5.0 + (-22.5) = -17.5 \text{ mm}$$

As there cannot be a 'negative' storage, this value is set to zero. The 'M' values for the rest of the months are determined similarly. In this example, all months other than June have negative cumulative storage requirements. The largest cumulative value is selected as the required storage. In this case the largest storage (V) is in June and is 5.0 mm.

The wet weather storage can then be found by converting this 'depth' of irrigation to a volume. This is achieved by dividing by 1000 (to convert to metres) and multiplying by the nominated irrigation area size as follows:

$$\begin{aligned} \text{Storage} &= \frac{5.0 \times 1480}{1000} \\ &= 7.4 \text{ m}^3 \end{aligned}$$

This is equivalent to about three standard size septic tanks.

Note: for areas that require several consecutive months of storage, the cumulative storage can become quite large. If the cumulative storage does not return to zero or a negative value after summing the monthly values over the entire year, then the nominated irrigation area is not large enough and should be increased before repeating the water balance.

**Table A6.1: Monthly Water Balance used to Determine Wet Weather Storage for a Medium Rainfall Region with a Nominated Irrigation Area of 1480 m<sup>2</sup>**

Design Wastewater Flow	(Q)	l/day	1000													
Design Percolation Rate	(R)	mm/wk	5													
Land area	(L)	m <sup>2</sup>	1480													
<b>Parameter</b>	<b>Symbol</b>	<b>Formula</b>	<b>Units</b>	<b>Jan</b>	<b>Feb</b>	<b>Mar</b>	<b>Apr</b>	<b>May</b>	<b>Jun</b>	<b>Jul</b>	<b>Aug</b>	<b>Sep</b>	<b>Oct</b>	<b>Nov</b>	<b>Dec</b>	<b>total</b>
Days in month	(D)	-	days	31	28	31	30	31	<b>30</b>	31	31	30	31	30	31	365
Precipitation	(P)	-	mm/month	74	69	70	66	63	<b>67</b>	46	37	43	60	52	64	711
Evaporation	(E)	-	mm/month	195.3	159.6	145.7	117	96.1	<b>87</b>	96.1	127.1	150	176.7	180	217	1747.6
Crop factor	(C)	-	-	0.7	0.7	0.7	0.7	0.7	<b>0.7</b>	0.7	0.7	0.7	0.7	0.7	0.7	-
<b>Inputs</b>																
Precipitation	(P)	-	mm/month	74	69	70	66	63	<b>67</b>	46	37	43	60	52	64	711
Effluent irrigation	(W)	(Q x D) / L	mm/month	20.9	18.9	20.9	20.3	20.9	<b>20.3</b>	20.9	20.9	20.3	20.9	20.3	20.9	246.6
Inputs		(P+W)	mm/month	94.9	87.9	90.9	86.3	83.9	<b>87.3</b>	66.9	57.9	63.3	80.9	72.3	84.9	957.6
<b>Outputs</b>																
Evapotranspiration	(ET)	E x C	mm/month	136.7	111.7	102.0	81.9	67.3	<b>60.9</b>	67.3	89.0	105.0	123.7	126.0	151.9	1223.3
Percolation	(B)	(R / 7) x D	mm/month	22.1	20.0	22.1	21.4	22.1	<b>21.4</b>	22.1	22.1	21.4	22.1	21.4	22.1	260.7
Outputs		(ET+B)	mm/month	158.9	131.7	124.1	103.3	89.4	<b>82.3</b>	89.4	111.1	126.4	145.8	147.4	174.0	1484.0
<b>Storage</b>																
Storage	(S)	(P + W) - (ET + B)	mm/month	-63.9	-43.8	-33.2	-17.1	-5.5	<b>5.0</b>	-22.5	-53.2	-63.2	-64.9	-75.2	-89.1	-
Cumulative storage	(M)	-	mm	0.0	0.0	0.0	0.0	0.0	<b>5.0</b>	0.0	0.0	0.0	0.0	0.0	0.0	-
<b>Storage</b>																
<b>Storage</b>	<b>(V)</b>	<b>largest M</b>	<b>mm</b>	<b>5.0</b>												
		<b>(V x L)/1000</b>	<b>m<sup>3</sup></b>	<b>7.4</b>												



## MINIMUM AREA METHOD

Using the minimum area method allows you to estimate the minimum permissible irrigation area, based on the hydraulic loading and the climate of the region of interest. It should, however, be noted that there are limitations to this method of estimation.

One of the major limitations is that the wet weather storage requirement is a maximum when the irrigation area is a minimum. This could be desirable in low rainfall areas, where storage will not usually be an issue, but in higher rainfall areas it is usually beneficial to use the nominated area method to derive an acceptable balance between irrigation area and wet weather storage requirements (however, in certain high rainfall areas there are limits to how much this relationship can be manipulated).

The estimation of the minimum irrigation area required based on the hydraulic loading is a two-step process:

- determine the water balance, which allows you to determine the wastewater application rate, then
- calculate the land application area required.

### Water Balance

The methodology is similar to that used for the nominated area method, but the key difference is that an 'average annual liquid loading rate' (H) needs to be estimated (as a land area has not been nominated to enable direct determination of the loading for each month).

A monthly water balance provides an estimate of the allowable irrigation rate, which can then be used to calculate the irrigation area.

Table A6.2 contains the water balance for the property.

### Inputs

- Precipitation (P) - The 50th percentile monthly precipitation is entered into the water balance. Historical data was obtained from the Bureau of Meteorology. For June the design precipitation is 67 mm.
- Possible Effluent Irrigation (W) - The wastewater that may be applied is calculated as the unknown in the water balance, as:

$$\text{Wastewater Applied} = \text{Evapotranspiration} + \text{Percolation} - \text{Design Precipitation}$$

$$\text{Or } W = ET + B - P$$

This is *not* the amount of wastewater that is generated, but simply an indication of how much may be applied. Wastewater is usually generated at a fairly constant rate throughout the year, not just when climatic conditions favour its irrigation.

### Outputs

- Evapotranspiration (ET) - Monthly evapotranspiration is estimated to be a certain percentage of the monthly evaporation known as the 'crop factor'. The crop factor may vary depending on the type of plant being grown, the area of the state where the irrigation area is placed, the time of the year and the exposure of the site. For lawn and turf, the crop factor varies between about 0.6 and 0.8, for shrubs the value is about 0.5 and for forests it is about 1.0. An average value of 0.7 will be used for this example. Take a conservative approach when choosing a crop factor unless studies show otherwise. Further information may be obtained from the Organic Waste Recycling Unit of NSW Agriculture. Historical monthly evaporation data is obtained from the Bureau of Meteorology. For June the determination of ET is as follows:

$$ET = 87 \times 0.7 = 60.9 \text{ mm/month}$$

- Percolation (B) - A nominal weekly percolation rate of 5 mm is entered into the water balance to allow for leaching of salts out of the root zone. This is converted to a monthly rate by dividing by seven (to get daily percolation) and multiplying by the number of days in each month to get a monthly value. For June this is as follows:

$$B = (5 / 7) \times 30 = 21.4 \text{ mm/month}$$

### Annual average liquid loading rate

- Value H - This is the sum of W over the year, and represents the total amount of wastewater that may be applied per year. This value is used to determine the land application area required based on hydraulic loading. For this example, H equals 773 mm.

**Table A6.2: Minimum Area Method Water Balance and Wet Weather Storage Calculations**

Design Wastewater Flow	(Q)	l/day	1000													
Design Percolation Rate	(R)	mm/wk	5													
<b>Parameter</b>	<b>Symbol</b>	<b>Formula</b>	<b>Units</b>	<b>Jan</b>	<b>Feb</b>	<b>Mar</b>	<b>Apr</b>	<b>May</b>	<b>Jun</b>	<b>Jul</b>	<b>Aug</b>	<b>Sep</b>	<b>Oct</b>	<b>Nov</b>	<b>Dec</b>	<b>total</b>
Days in month	(D)	-	days	31	28	31	30	31	<b>30</b>	31	31	30	31	30	31	365
Precipitation	(P)	-	mm/month	74	69	70	66	63	<b>67</b>	46	37	43	60	52	64	711
Evaporation	(E)	-	mm/month	195.3	159.6	145.7	117	96.1	<b>87</b>	96.1	127.1	150	176.7	180	217	1747.6
Crop factor	(C)	-	-	0.7	0.7	0.7	0.7	0.7	<b>0.7</b>	0.7	0.7	0.7	0.7	0.7	0.7	-
<b>Outputs</b>																
Evapotranspiration	(ET)	E x C	mm/month	136.7	111.7	102.0	81.9	67.3	<b>60.9</b>	67.3	89.0	105.0	123.7	126.0	151.9	1223.3
Percolation	(B)	(R / 7) x D	mm/month	22.1	20.0	22.1	21.4	22.1	<b>21.4</b>	22.1	22.1	21.4	22.1	21.4	22.1	260.7
Outputs		(ET+B)	mm/month	158.9	131.7	124.1	103.3	89.4	<b>82.3</b>	89.4	111.1	126.4	145.8	147.4	174.0	1484.0
<b>Inputs</b>																
Precipitation	(P)	-	mm/month	74	69	70	66	63	<b>67</b>	46	37	43	60	52	64	711
Possible Effluent irrigation	(W)	(ET + B) - P	mm/month	84.9	62.7	54.1	37.3	26.4	<b>15.3</b>	43.4	74.1	83.4	85.8	95.4	110.0	<b>773.0</b>
Actual Effluent Production	(I)	H / 12	mm/month	64.4	64.4	64.4	64.4	64.4	<b>64.4</b>	64.4	64.4	64.4	64.4	64.4	64.4	773.0
Inputs		(P + I)	mm/month	138.4	133.4	134.4	130.4	127.4	<b>131.4</b>	110.4	101.4	107.4	124.4	116.4	128.4	1484.0
<b>Storage</b>																
Storage	(S)	(P + I) - (ET + B)	mm/month	-20.4	1.7	10.3	27.1	38.0	<b>49.1</b>	21.0	-9.7	-19.0	-21.4	-31.0	-45.6	-
Cumulative storage	(M)	-	mm	0.0	1.7	12.0	39.1	77.1	126.2	<b>147.2</b>	137.5	118.5	97.1	66.1	20.4	-
<b>Irrigation Area</b>																
<b>(L)</b>	<b>(L)</b>	<b>365 x Q / H</b>	<b>m<sup>2</sup></b>	<b>472</b>												
<b>Storage</b>																
<b>(V)</b>	<b>(V)</b>	<b>largest M</b>	<b>mm</b>	<b>147.2</b>												
		<b>(V x L) / 1000</b>	<b>m<sup>3</sup></b>	<b>69.5</b>												

H = sum of W

### Minimum Irrigation Area Required

Based on the average annual liquid loading, H (the amount of wastewater that may be applied per year, in this case 773 mm/yr), the land area required for complete use of the hydraulic load based on historical data is:

$$A = \frac{365 \times Q}{H}$$

Where  
A = land area (m<sup>2</sup>)  
Q = average treated wastewater flow rate (L/d)  
H = average annual liquid loading (mm/yr)

In this case:  
Q = 1000 L/d  
H = 773 mm/yr

$$A = \frac{365 \times 1000}{773}$$
$$= 472 \text{ m}^2$$

It is obvious that this area cannot be used, as it is much smaller than the limiting area of 1480m<sup>2</sup> - the area required for the nitrogen.

### Maximum Wet Weather Storage Volume Required

The wet weather storage requirement estimated from this method will be a maximum. The estimation method is based on the water balance 'inputs equal outputs'. However, problems are encountered when the inputs exceed the outputs, and this is normally demonstrated when systems are overloaded and effluent is exported from the site as surface run off. Storage is needed for these times, and the water balance can be rewritten as:

$$\text{inputs} - \text{outputs} = \text{storage}$$

This is represented in Table A6.2 as follows:

- Actual Effluent Production (I) - The wastewater available per month is found by dividing the annual average liquid loading rate (H) by 12. This is based on the fact that wastewater is usually generated at a fairly constant rate throughout the year, not just when climatic conditions favour its irrigation.
- Storage (S) - Storage is found by subtracting the outputs from the system from the inputs to the system. A positive value indicates that wastewater must be stored during that month.
- Cumulative Storage (M) - Cumulative storage needs to be determined when more than a single consecutive month requires storage. The first positive storage (S) value for the year should be identified and entered as the cumulative storage for that month. In this

case February is the first positive storage. The following values are summed until the storage returns to zero. For example, the cumulative storage value for March is the storage value for March (10.3 mm) plus the cumulative storage value for February (1.7 mm). This process is continued for the remaining months.

Using this method, the cumulative storage should always return to zero on the month preceding the month with the first positive storage. In this case it is January. This represents the month of the year where the storage is 'empty'.

The maximum storage requirement hence corresponds to the largest value M, where the storage is 'full'.

The maximum total storage requirement M is found to be in July and is 147.2 mm per unit land application area. This value is converted to a storage volume by dividing by 1000 (to convert to metres) and multiplying by the land application area:

$$V = \frac{147.2 \text{ mm} \times 472 \text{ m}^2}{1000}$$
$$= 69.5 \text{ m}^3$$

Again, this calculation is included for information only, as for this example the minimum irrigation area based on hydraulic loading is not the limiting area.

## BALANCING THE IRRIGATION AREA AND WET WEATHER STORAGE

The size of the irrigation area can be increased to obtain a smaller wet weather storage volume by the nominated area method (this method should not be used to reduce the storage to less than three days). Figure A6.1 below demonstrates the relationship between irrigation area and storage volume for the medium rainfall property, and shows the minimum area required for nutrient loading as a dotted line at the 1480 m<sup>2</sup> irrigation area requirement, as well as the minimum recommended storage of three days.

The chart was obtained by using the nominated area method on several different areas. As can be seen, the results derived from the minimum area method give the smallest land area possible for the climatic conditions in the region, but this requires the largest storage. Increasing the land area subsequently reduces the storage required.

You can see that the relationship between storage and irrigation area is not linear. This means that the area cannot simply be doubled to get a halving in storage. As the chart shows, initial increases in irrigation area give quite good reductions in storage requirements, but for land area increases over about 1200 m<sup>2</sup> the reductions in storage are not as substantial.

**Figure A6.1: The Relationship between Irrigation Area and Storage Volume for the Medium Rainfall Property**

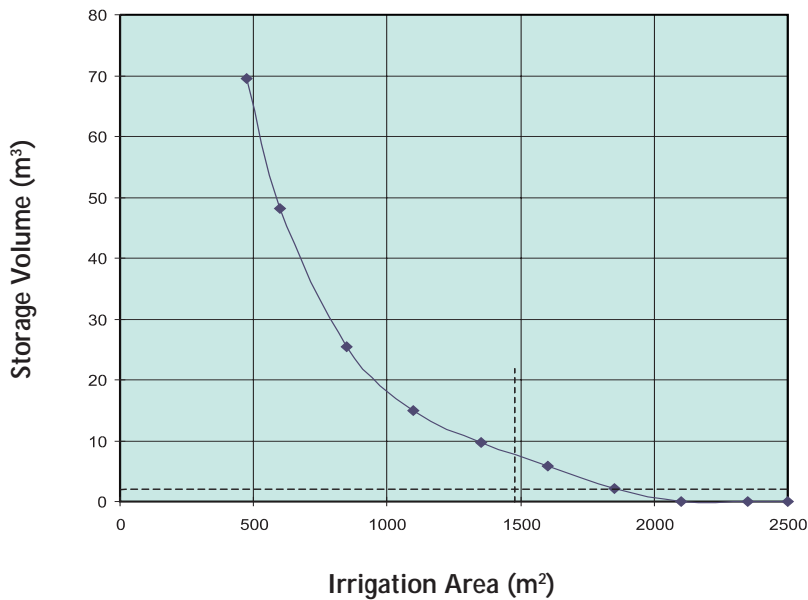

For certain climates there are months when precipitation (input) is more than evapotranspiration and percolation (output) combined. In these cases (using this model) no wastewater can be applied, and storage is required for the entire month. Increasing the land area does not change the storage requirements for these months. Figure A6.2 below shows the relationship between storage and area requirements for a high rainfall area.

The chart was obtained using both the minimum area and nominated area methods, as for the medium rainfall area. The design crop factor was increased to 0.8 to account for the better growing conditions with the other difference being the climate information of precipitation and evaporation. The design percolation is the same as that used for the medium rainfall area. The change in axis scales between Figures A6.1 and A6.2 should be noted.

The precipitation in the high rainfall area exceeds evapotranspiration for eight months of the year, and most of the effluent produced for those months will have to be stored. This is reflected by the extremely high storage requirement of about 210 - 230 m<sup>3</sup>. Also, increases in irrigation area only affect storage requirements in those months with an evapotranspiration excess, in this case only four months of the year. This is reflected by the minimal reductions in storage requirement with increases in irrigation area up to 6500 m<sup>2</sup> (in fact, calculations show that *any* increase in irrigation area will not decrease the storage requirement further for this example).

The use of traditional on-site treatment is not appropriate, and consideration should be given to the options provided in Section 6.

Figure A6.2: The relationship between storage and area requirements for a high rainfall area

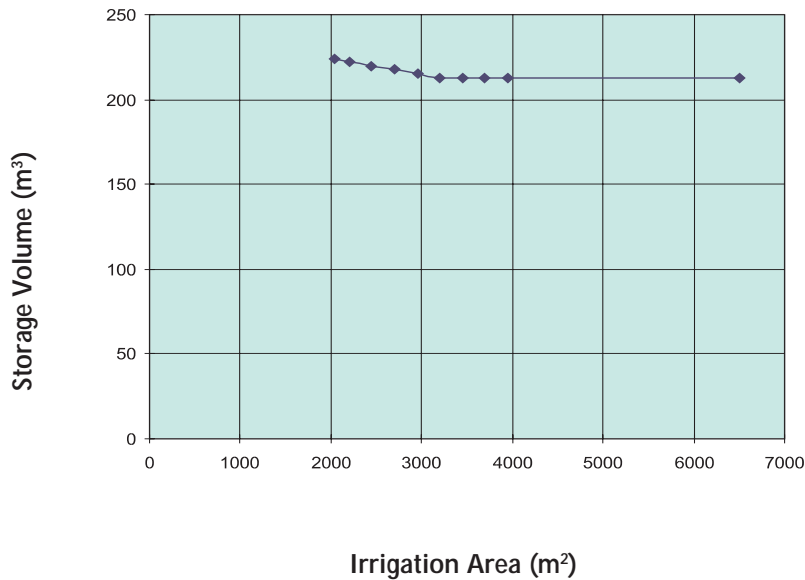

## CONCLUSIONS

The following conclusions can be drawn from the above examples:

- The suitability of a site for on-site sewage management should first be determined by a site evaluation. These calculations are based on the assumption that there are no limiting site or soil features.
- Water balance calculations provide only an estimate of irrigation area and storage requirements. Even small changes in the various inputs to the water balance equation (percolation, precipitation, evaporation and the crop factor) can lead to large differences in the final estimates. The calculations are only a model of very complex processes, and as such, a conservative approach should be taken.
- Either the nutrient or hydraulic loading could be the limiting factor for an irrigation area. Use both methods to get an estimate.
- Reductions in nutrient and hydraulic loadings can lead to significant reductions in area and storage requirements. This may be especially relevant when you are designing a system to upgrade or replace an existing system that has failed.
- Wet weather storage requirements can be excessive in areas with high rainfall compared to evaporation. Increasing the irrigation area might not lead to significant reductions in storage. Other options for sewage management in high rainfall areas are included in Section 6.

## APPENDIX 7

### VEGETATION SUITABLE FOR LAND APPLICATION AREAS

Botanical Name	Approximate Height	Common Name or Variety	
<b>Grasses</b>			
<i>Carex spp.</i>	40 - 80 cm	Available as lawn turf	
<i>Lomandra longifolia</i>			
<i>Microlaena stipoides</i>			
<i>Oplismenus imbecillis</i>			
<i>Pennisetum alopecuroides</i>			
<i>Poa lab</i>			
<i>Stipa spp.</i>			
<b>Ground cover/climbers</b>			
<i>Hibbertia scandens</i>	Prostrate Climber	Snake vine	
<i>Hibbertia stellaris</i>		Dusky coral pea	
<i>Isotoma fluviatilis</i>			
<i>Kennedia rubicunda</i>		Native violet	
<i>Scaevola albida</i>			
<i>Scaevola ramosissima</i>			
<i>Veronica plebeia</i>			
<i>Viola hederacea</i>			
<b>Sedges/grasses/small plants</b>			
<i>Anigozanthus flavidus</i>	2m	Kangaroo Paw	
<i>Baumea acuta</i>	Sedge	Christmas Bell Christmas Bell Native Daisy	
<i>Baumea articulata</i>			
<i>Baumea juncea</i>			
<i>Baumea nuda</i>			
<i>Baumea rubiginosa</i>			
<i>Baumea teretifolia</i>			
<i>Blandfordia grandiflora</i>			30-90cm
<i>Blandfordia nobilis</i>			30-90cm
<i>Brachyscome diversifolia</i>			Clump
<i>Carex appressa</i>			Sedge
<i>Cotula coronopifolia</i>	10-20cm	Waterbutton	
<i>Crinum pedunculatum</i>	<2m	Swamp Lily	
<i>Cyperus polystachyos</i>	Sedge	Blue Flax Lily	
<i>Dianella caerulea</i>	Low plant		
<i>Epacris microphylla</i>	50cm -1m		
<b>Ferns</b>			
<i>Gahnia spp.</i>	Tall Grass	Native Iris Native Iris Native Iris	
<i>Juncus spp.</i>	0.5 m Rush		
<i>Lobelia trigonocaulis</i>	5-10cm		
<i>Lomandra spp.</i>	Grass		
<i>Patersonia fragilis</i>			
<i>Patersonia glabrata</i>			
<i>Patersonia occidentalis</i>			
<i>Ranunculus graniticola</i>	5cm		
<i>Restio australis</i>	Reed		
<i>Restio tetraphyllus</i>	1m		
<i>Sowerbaea juncea</i>	Sedge	Rush Lily	
<i>Tetradlea juncea</i>	<30cm	Tall Yellow Eye	
<i>Xyris operculata</i>	<1m		



Botanical Name	Approximate Height	Common Name or Variety
<b>Shrubs</b>		
<i>Agonis flexuosa nana</i>		
<i>Baekea linifolia</i>	1 - 2.5 m	
<i>Baekea utilis</i>	1-2.5 m	
<i>Baekea virgata</i>	< 4 m	
<i>Banksia aemula</i>	1 - 7 m	
<i>Banksia robur</i>	0.5 - 2 m	
<i>Bauera ruboides</i>	0.5 - 1.5 m	
<i>Callistemon</i>	2 - 3 m	Burgundy
<i>Callistemon</i>	2 - 4 m	Eureka
<i>Callistemon</i>	3 - 4 m	Harkness
<i>Callistemon</i>	3 - 4.5 m	Kings Park Special
<i>Callistemon</i>	2 - 3 m	Mauve Mist
<i>Callistemon</i>	1 - 2.5 m	Red Clusters
<i>Callistemon</i>	2 - 3 m	Reeves Pink
<i>Callistemon citrinus</i>	50 - 80 cm	Austraflora Firebrand
<i>Callistemon citrinus</i>	2 - 4 m	Splendens
<i>Callistemon citrinus</i>	60cm - 1m	White Ice
<i>Callistemon linearis</i>	1 - 3 m	
<i>Callistemon macropunctatus</i>	2 - 4 m	
<i>Callistemon pachyphyllus</i>	2 - 3 m	
<i>Callistemon pallidus</i>	1.5 - 4 m	
<i>Callistemon paludosus</i>	3 - 7 m	
<i>Callistemon pinifolius</i>	1 - 3 m	
<i>Callistemon rigidus</i>	1.5 - 2.5 m	
<i>Callistemon salignus</i>	3 - 10m	
<i>Callistemon shiresii</i>	4 - 8 m	
<i>Callistemon sieberi</i>	1.5 - 2 m	
<i>Callistemon sieberi</i>	50 - 80 cm	Austraflora Little Cobber
<i>Callistemon subulatus</i>	1 - 2 m	
<i>Callistemon viminalis</i>	1 - 2 m	Captain Cook
<i>Callistemon viminalis</i>	5 - 10 m	Dawson River
<i>Callistemon viminalis</i>	3 - 5 m	Hannah Ray
<i>Callistemon viminalis</i>	50 cm - 1 m	Little John
<i>Callistemon viminalis</i>	1.5 - 2 m	Rose Opal
<i>Callistemon viminalis</i>	2 - 3 m	Western Glory
<i>Goodenia ovata</i>	1 - 1.5 m	
<i>Hibiscus diversifolius</i>	1 - 2 m	Swamp hibiscus
<i>Kunzea capitata</i>	1 - 2 m	
<i>Leptospermum flavescens</i>	< 2 m	Tea-tree
<i>Leptospermum juniperinum</i>	1 m	Tea-tree
<i>Leptospermum lanigerum</i>	1 - 2 m	Woolly tea-tree
<i>Leptospermum squarrosum</i>	< 2 m	Tea-tree
<i>Melaleuca alternifolia</i>	4 - 7 m	
<i>Melaleuca decussata</i>	1 - 2 m	Cross-leaved honey myrtle
<i>Melaleuca lanceolata</i>	4 - 6 m	
<i>Melaleuca squamea</i>	1 - 2 m	
<i>Melaleuca thymifolia</i>		

Botanical Name	Approx Height	Common Name or Variety
<b>Trees</b>		
<i>Acacia elongata</i>	> 2 m	
<i>Acacia floribunda</i>	2 - 4 m	Gossamer wattle
<i>Agonis flexuosa</i>	5 - 6 m	Willow myrtle
<i>Allocasuarina diminuta</i>	1.5 m	
<i>Allocasuarina paludosa</i>	0.5 - 2 m	
<i>Angophora floribunda</i>	Large tree	
<i>Angophora subvelutina</i>	Large tree	
<i>Callicoma serratifolia</i>	< 4m	
<i>Casuarina cunninghamiana</i>	10 - 30 m	River she-oak
<i>Casuarina glauca</i>	6 - 12 m	Swamp oak
<i>Elaeocarpus reticulatis</i>	Large tree	Blueberry ash
<i>Eucalyptus amplifolia</i>	Large tree	
<i>Eucalyptus botryoides (coastal areas)</i>	10 - 30 m	
<i>Eucalyptus camaldulensis (west of ranges)</i>	15 - 20 m	River red gum
<i>Eucalyptus deanei</i>	Large tree	Blue Mountains blue gum
<i>Eucalyptus elata</i>	Large tree	River Peppermint
<i>Eucalyptus grandis</i>	10 - 20 m	Flooded gum
<i>Eucalyptus longifolia</i>	20 m	Woollybutt
<i>Eucalyptus pilularis</i>	30 - 40 m	Blackbutt
<i>Eucalyptus punctata</i>	< 35 m	Greygum
<i>Eucalyptus robusta</i>	20 - 30 m	Swamp mahogany
<i>Eucalyptus saligna (coastal)</i>	30 - 50 m	Sydney blue gum
<i>Eucalyptus tereticornis</i>	30 - 40 m	Forest red gum
<i>Eucalyptus viminalis (ranges)</i>	20 - 40 m	Ribbon gum
<i>Acmena smithii</i>	10 - 20 m	Lilli pilli
<i>Flindersia australis</i>	< 40 m	Native teak
<i>Hymenosporum flavuum</i>	3 - 6 m	Native frangipani
<i>Melaleuca armillaris</i>	3 - 4 m	Bracelet honey myrtle
<i>Melaleuca decora</i>	4 - 7 m	
<i>Melaleuca ericifolia</i>	6 m	
<i>Melaleuca halmaturorum</i>	4 - 6 m	
<i>Melaleuca hypericifolia</i>	2 - 3 m	
<i>Melaleuca linariifolia</i>	4 - 8 m	Snow in summer
<i>Melaleuca quinquenervia</i>	5 - 7 m	Broad paperbark
<i>Melaleuca squarrosa</i>	6 m	
<i>Melaleuca stypheloides</i>	6 - 15 m	
<i>Melia azedarach</i>	15 - 20 m	
<i>Pittosporum spp.</i>		
<i>Syzygium paniculatum</i>	8 - 10 m	Bush cherry
<i>Tristania laurina</i>	5 - 15 m	Kanuka
<i>Viminaria juncea</i>	2 - 3 m	Golden spray

Source: Australian Plants Society

## APPENDIX 8

### PUBLIC INFORMATION BROCHURES

The following brochures:

*Managing Wastewater in Your Backyard*  
*Your Aerated Wastewater Treatment System*  
*Your Waterless Composting Toilet*  
*Your Septic System*  
*Your Land Application Area*

may be photocopied and distributed whenever needed.

## ON-SITE SEWAGE MANAGEMENT SYSTEMS

If you live in or rent a house that is not connected to the main sewer then chances are that your yard contains an on-site sewage management system. If this is the case then you have a special responsibility to ensure that it is working as well as it can.

The aim of this pamphlet is to introduce you to some of the most popular types of on-site sewage management systems and provide some general information to help you maintain your system effectively. You should find out what type of system you have and how it works.

More information can be obtained from the pamphlets:

Your Septic System  
Your Aerated Wastewater Treatment System  
Your Composting Toilet  
Your Land Application Area

You can get a copy of these pamphlets from your local council or the address marked on the back of this pamphlet.

It is important to keep in mind that maintenance needs to be performed properly and regularly. Poorly maintained on-site sewage management systems can significantly affect you and your family's health as well as the local environment.

### What is an on-site sewage management system?

A domestic on-site sewage management system is made up of various components which - if properly designed, installed and maintained - allow the treatment and utilisation of wastewater from a house, completely within the boundary of the property.

Wastewater may be blackwater (toilet waste), or greywater (water from showers, sinks, and washing machines), or a combination of both.

Partial on-site systems - eg. pump out and common effluent systems (CES) - also exist. These usually involve the preliminary on-site treatment of wastewater in a septic tank, followed by collection and transport of the treated wastewater to an off-site management facility. Pump out systems use road tankers to transport the effluent, and CES use a network of small diameter pipes.

### How does an on-site sewage management system work?

For complete on-site systems there are two main processes:

1. treatment of wastewater to a certain standard
2. its application to a dedicated area of land.

The type of application permitted depends on the quality of treatment, although you should try to avoid contact with all treated and untreated wastewater, and thoroughly wash affected areas if contact does occur.

Treatment and application can be carried out using various methods:

#### *Septic Tank*

Septic tanks treat both greywater and blackwater, but they provide only limited treatment through the settling of solids and the flotation of fats and greases. Bacteria in the tank break down the solids over a period of time. Wastewater that has been treated in a septic tank can only be applied to land through a covered soil absorption system, as the effluent is still too contaminated for above ground or near surface irrigation.

#### *AWTS*

Aerated wastewater treatment systems (AWTS) treat all household wastewater and have several treatment compartments. The first is like a septic tank, but in the second compartment air is mixed with the wastewater to assist bacteria to break down solids. A third compartment allows settling of more solids and a final chlorination contact chamber allows disinfection. Some AWTS are constructed with all the compartments inside a single tank. The effluent produced may be surface or sub-surface irrigated in a dedicated area.

#### *Composting Toilets*

Composting toilets collect and treat toilet waste only. Water from the shower, sinks and the washing machine needs to be treated separately (for example in a septic tank or AWTS as above). The compost produced by a composting toilet has special requirements but is usually buried on-site.

These are just some of the treatment and application methods available, and there are many other types such as sand filter beds, wetlands, and amended earth mounds. Your local council or the NSW Department of Health have more information on these systems if you need it.

### Regulations and recommendations

The NSW Department of Health determines the design and structural requirements for treatment systems for single households. Local councils are primarily responsible for approving the installation of smaller domestic septic tank systems, composting toilets and AWTSs in their area, and are also responsible for approving land application areas. The NSW Environment Protection Authority approves larger systems.

The design and installation of on-site sewage management systems, including plumbing and drainage, should only be carried out by suitably qualified or experienced people. Care is needed to ensure correct sizing of the treatment system and application area.

Heavy fines may be imposed under the Clean Waters Act if wastewater is not managed properly.

### Keeping your on-site sewage management system operating well

What you put down your drains and toilets has a lot to do with how well your system performs. Maintenance of your sewage management system also needs to be done well and on-time. The following is a guide to the types of things you should and should not do with your system.

## DO

- ✓ Learn how your sewage management system works and its operational and maintenance requirements.
- ✓ Learn the location and layout of your sewage management system.
- ✓ Have your AWTS (if installed) inspected and serviced four times per year by an approved contractor. Other systems should be inspected at least once every year. Assessment should be applicable to the system design.
- ✓ Keep a record of desludgings, inspections, and other maintenance.
- ✓ Have your septic tank or AWTS desludged every three years to prevent sludge build up, which may 'clog' the pipes.
- ✓ Conserve water. Conservative water use around the house will reduce the amount of wastewater which is produced and needs to be treated.
- ✓ Discuss with your local council the adequacy of your existing sewage management system if you are considering house extensions for increased occupancy.

## DON'T

- ✗ Don't let children or pets play on land application areas.
- ✗ Don't water fruit and vegetables with effluent.
- ✗ Don't extract untreated groundwater for cooking and drinking.
- ✗ Don't put large quantities of bleaches, disinfectants, whiteners, nappy soakers and spot removers into your system via the sink, washing machine or toilet.
- ✗ Don't allow any foreign materials such as nappies, sanitary napkins, condoms and other hygiene products to enter the system.
- ✗ Don't put fats and oils down the drain and keep food waste out of your system.
- ✗ Don't install or use a garbage grinder or spa bath if your system is not designed for it.

## Reducing water usage

Reducing water usage will lessen the likelihood of problems such as overloading with your septic system. Overloading may result in wastewater backing up into your house, contamination of your yard with improperly treated effluent, and effluent from your system contaminating groundwater or a nearby waterway.

Your sewage management system is also unable to cope with large volumes of water such as several showers or loads of washing over a short period of time. You should try to avoid these 'shock loads' by ensuring water use is spread more evenly throughout the day and week.

## HELP PROTECT YOUR HEALTH AND THE ENVIRONMENT

Poorly maintained sewage management systems are a serious source of water pollution and may present health risks, cause odours and attract vermin and insects.

By looking after your management system you can do your part in helping to protect the environment and the health of you and your community.

For more information please contact:

# Managing Wastewater In Your Backyard

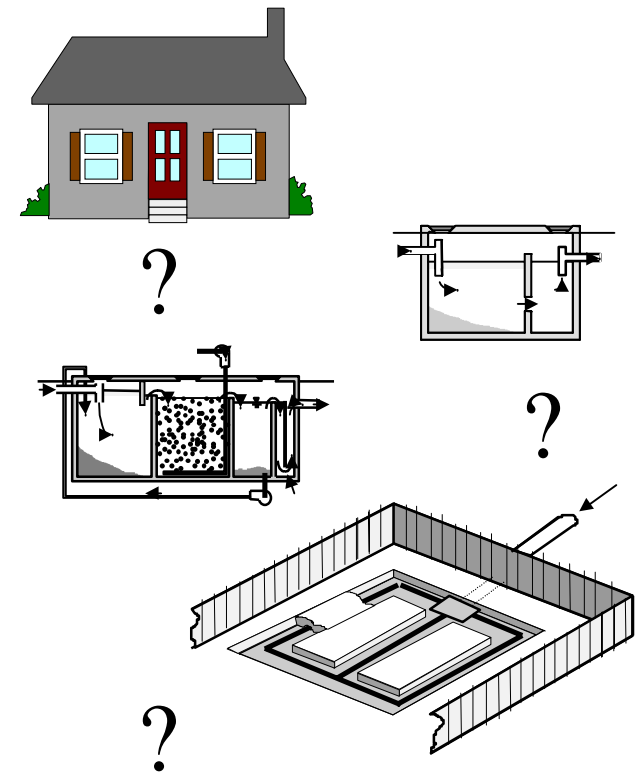

# Aerated Wastewater Treatment Systems (AWTS)

In unsewered areas, the proper treatment and utilisation of household wastewater on-site is critical in preserving the health of the public and the environment. AWTS have been developed as a way of achieving this.

## What is an AWTS?

An AWTS is a purpose built system used for the treatment of sewage and liquid wastes from a single household or multiple dwellings.

It consists of a series of treatment chambers combined with an irrigation system. An AWTS enables people living in unsewered areas to treat and utilise their wastewater.

## How does an AWTS work?

Wastewater from a household is treated in stages in several separate chambers. The first chamber is similar to a conventional septic tank. The wastewater enters the chamber where the solids settle to the bottom and are retained in the tank forming a sludge layer. Scum collects at the top, and the partially clarified wastewater flows into a second chamber. Here the wastewater is mixed with air

to assist bacteria to further treat it. A third chamber allows additional clarification through the settling of solids, which are returned for further treatment to either the septic chamber (as shown) or to the aeration chamber. The clarified effluent is disinfected in another chamber (usually by chlorination) before irrigation can take place.

Bacteria in the first chamber break down the solid matter in the sludge and scum layers. Material that cannot be fully broken down gradually builds up in the chamber and must be pumped out periodically.

## Regulations and recommendations

Local councils are primarily responsible for approving the smaller, domestic AWTSs in their area. The Environment Protection Authority (EPA) approves larger units, whilst the NSW Department of Health determines the design and structural requirements for all AWTSs.

At present AWTSs need to be serviced quarterly by an approved contractor at a cost to the owner. Local councils should also maintain a register of the servicing of each system within their area.

AWTSs should be fitted with an alarm having visual and audible components to indicate mechanical and electrical equipment malfunctions. The alarm should provide a signal adjacent to the alarm and at a relevant position inside the house. The alarm should incorporate a warning lamp which may only be reset by the service agent.

## Maintaining your AWTS

The effectiveness of the system will, in part, depend on how it is used and maintained. The following is a guide on good maintenance procedures that you should follow:

## DO

- ✓ Have your AWTS inspected and serviced four times per year by an approved contractor. Assessment should be applicable to the system design.
- ✓ Have your system service include assessment of sludge and scum levels in all tanks, and performance of irrigation areas.
- ✓ Have all your tanks desludged at least every three years.
- ✓ Have your disinfection chamber inspected and tested quarterly to ensure correct disinfectant levels.
- ✓ Have your grease trap (if installed) cleaned out at least every two months.
- ✓ Keep a record of pumping, inspections, and other maintenance.
- ✓ Learn the location and layout of your AWTS and land application area.
- ✓ Use biodegradable liquid detergents such as concentrates with low sodium and phosphorous levels.
- ✓ Conserve water.

## DON'T

- ✗ Don't put bleaches, disinfectants, whiteners, nappy soakers and spot removers in large quantities into your AWTS via the sink, washing machine or toilet.
- ✗ Don't allow any foreign materials such as nappies, sanitary napkins, condoms and other hygiene products to enter the system.
- ✗ Don't use more than the recommended amounts of detergents.
- ✗ Don't put fats and oils down the drain and keep food waste out of your system.
- ✗ Don't switch off power to the AWTS, even if you are going on holidays

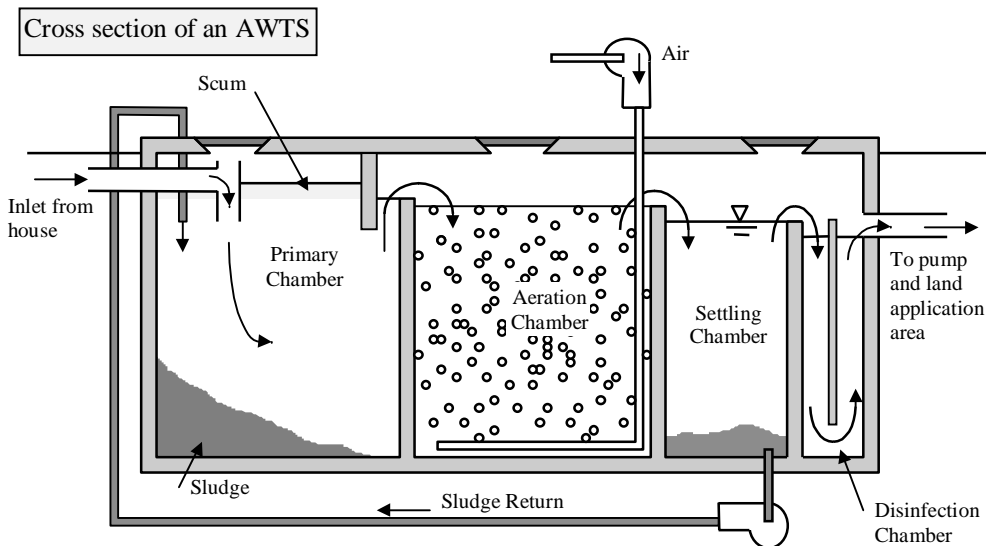

## Reducing water usage

Reducing water usage will lessen the likelihood of problems such as overloading with your AWTS. Overloading may result in wastewater backing up into your house, contamination of your yard with improperly treated effluent, and effluent from your system entering a nearby river, creek or dam.

Conservative water use around the house will reduce the amount of wastewater which is produced and needs to be treated.

Your AWTS is also unable to cope with large volumes of water such as several showers or loads of washing over a short period of time. You should try to avoid these 'shock loads' by ensuring water use is spread more evenly throughout the day and week.

## Warning signs

You can look out for a few warning signs that signal to you that there are troubles with your AWTS. Ensure that these problems are attended to immediately to protect your health and the environment.

Look out for the following warning signs:

- 🔔 Water that drains too slowly.
- 🔔 Drain pipes that gurgle or make noises when air bubbles are forced back through the system.
- 🔔 Sewage smells, this indicates a serious problem.
- 🔔 Water backing up into your sink which may indicate that your system is already failing.
- 🔔 Wastewater pooling over the land application area.
- 🔔 Black coloured effluent in the aerated tank.
- 🔔 Excess noise from the blower or pumping equipment
- 🔔 Poor vegetation growth in irrigated area.

Odour problems from a vent on the AWTS can be a result of slow or inadequate breakdown of solids. Call a technician to service the system.

## HELP PROTECT YOUR HEALTH AND THE ENVIRONMENT

Poorly maintained AWTSs are a serious source of water pollution and may present health risks, cause odours and attract vermin and insects.

By looking after your treatment system you can do your part in helping to protect the environment and the health of you and your family.

If you would like more information please contact:

# Your Aerated Wastewater Treatment System

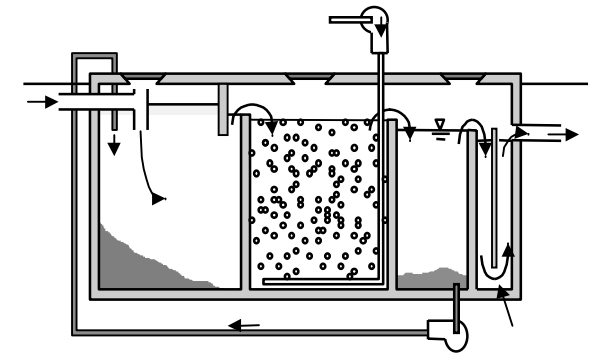

## WATERLESS COMPOSTING TOILETS

In unsewered areas, the proper on-site treatment and reuse of human wastes and household wastewater is critical in preserving the health of the public and the environment. Waterless composting toilets have been developed as a way of achieving this.

### What is a waterless composting toilet?

Waterless composting toilets (also known as humus closets or biological toilets) are waterless systems which rely on the principles of composting by micro-organisms to decompose human waste, paper and other materials into humus.

Systems are either continuous or batch. Continuous systems contain one chamber, whilst the batch systems contain several bins, with rotation occurring after each bin is filled. In both systems, chambers or bins are installed below floor level.

Waterless composting toilets do not treat wastewater from other sources such as showers, sinks, and washing machines (also known as 'greywater'), so an alternative system is required for this.

### How does a waterless composting toilet work?

There are several types of waterless composting toilet available, but the principles they use are basically the same. The description and diagram given here are for a single chamber continuous toilet.

Excreta (both urine and faeces) is collected in a sealed chamber beneath the toilet pedestal. Extra organic matter such as woodshavings, paper, or lawn clippings are added to create an ideal composting environment. Micro-organisms decompose the material, with around three quarters of it being converted to carbon dioxide and water vapour. Air drawn through the pile removes these gases and assists the micro-organisms.

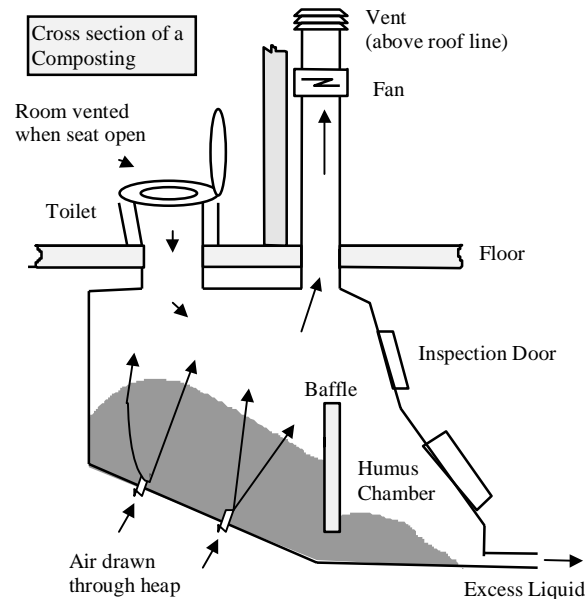

The remaining material slowly moves down a sloping floor by gravity as more material is added to the pile. It then moves under a dividing baffle into the humus chamber as friable compost after about a year.

Any excess liquids are drained and treated with the greywater. The compost produced is typically buried on-site.

The advantage of composting toilets is that they can be used on difficult sites as they do not require any water. National Parks and low usage camping areas with limited water supplies are common sites. They can also be used in single domestic premises and may be installed externally or within the dwelling.

### Regulations and recommendations

Before a composting toilet is installed at any unsewered domestic premises or unsewered site the owner/occupier should assess the site. Once satisfied that the site conditions will allow for a composting toilet, an approval can be sought from the local council. Houses may need to be specially designed to accommodate the units.

At present the Environment Protection Authority (EPA) and the NSW Department of Health recommend that the greywater from premises with composting toilets be managed as for the total waste stream. This means treatment and reuse facilities for greywater are required such as a greywater treatment system, septic tank, or aerated wastewater treatment system, and land application area.

Maintenance is the responsibility of the owner/occupier and is not normally subject to a maintenance contract. **The owner/occupier needs to be committed to the principles of composting.** Maintenance varies among composting toilets, and the needs of particular units should be specified clearly in a manual. If maintenance is not undertaken properly there is an increased risk of disease and odour generation.

It is recommended that units be serviced annually by an approved contractor. Annual servicing should include a check of the operation of the fan and the amount and spread of the compost within the composting chamber(s).

The minimum composting period should not be less than 12 months. Compost, including partially composted material must not be removed from the premises unless written consent from the local council is obtained. The local council may specify removal and application requirements. Unless otherwise directed by either the local council or the NSW Department of Health, the composted humus material is to be buried within the confines of the premises. The cover of soil over the deposited humus must be at least 75mm.

Compost must not be buried in an area used for the cultivation of crops for human consumption, unless:

- compost is placed in a separate lidded composting bin providing aeration, for at least three months with no further addition; OR
- compost has seasoned underground for at least three months.



## Location of composting toilets

Some of the toilet designs are suited to sites with a natural slope to allow access to the chamber(s) for the required maintenance.

A northern exposure is desirable for solar power generation, and free air movement above the roof is necessary for ventilation purposes.

## Maintaining your composting toilet

Householders should be aware of the stringent maintenance requirements of composting toilets.

The factors of water content, temperature, air flow patterns, pH, toilet usage rate, surface area of compost and oxygen penetration depth, all influence the rate and effectiveness of the biological breakdown of the waste materials.

Correct operation of composting toilets requires the addition of carbon-rich materials to the compost heap. Vegetable scraps and lawn clippings will assist the decomposition process through the addition of organic matter, and reduction in moisture content. Newspaper, sawdust and other absorbent materials provide bulk and spaces which allow increased aeration and ensures appropriate conditions are maintained.

Surface area in which the compost is spread should be large enough to allow composting to be completed before it is buried too deeply. Also, when there are high moisture levels in the compost, a very unpleasant odour is released.

The toilet seat should be kept closed when not in use to stop fly and insects entering the composting chamber.

## Maintenance Tips

The following is a guide on how to achieve the most from your system through good maintenance procedures:

- ✓ Record the commissioning date of each chamber for multi chamber systems
- ✓ Always close the toilet lid when the toilet is not in use to control fly breeding and ensure proper aeration of the pile
- ✓ Ensure that the material is spread evenly over the compost heap
- ✓ Always clean the pedestal by hand with minimal use of water and no use of disinfectants
- ✓ Consult the service agent if odour and vermin become excessive.
- ✓ Check moisture and temperature conditions regularly, to maintain optimum conditions for the composting process.
- ✓ Add organic and bulking material when required.

## HELP PROTECT YOUR HEALTH AND THE ENVIRONMENT

Poorly maintained composting toilets can be a serious source of pollution and may present health risks, cause odours and attract vermin and insects.

By looking after your composting toilet you can do your part in helping to protect the environment and the health of you and your family.

If you would like more information please contact:

# Your Waterless Composting Toilet

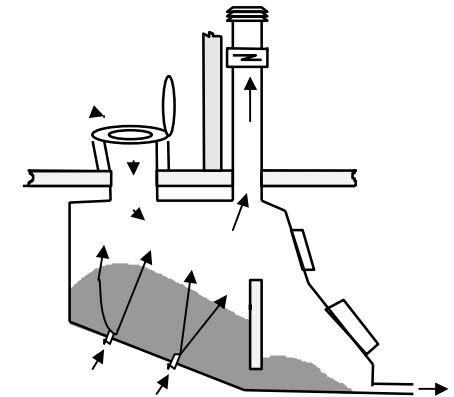

## SEPTIC SYSTEMS

In unsewered areas, the proper treatment and reuse of household wastewater on-site is critical in ensuring minimal impact to public health and the environment. Septic systems have been developed as a way of achieving this.

### What is a septic system?

A septic system consists of a septic tank combined with a soil absorption system and/or transpiration beds or pump out connections. The system enables people living in unsewered areas to treat and disperse their sewage.

A septic tank is a structurally sound watertight tank used for the treatment of sewage and liquid wastes from a single household or multiple dwellings.

### How does a septic system work?

All the wastewater from a household enters the tank. Most of the solids settle to the bottom and are retained in the tank forming a sludge layer, whilst fats and greases collect at the top in a scum layer.

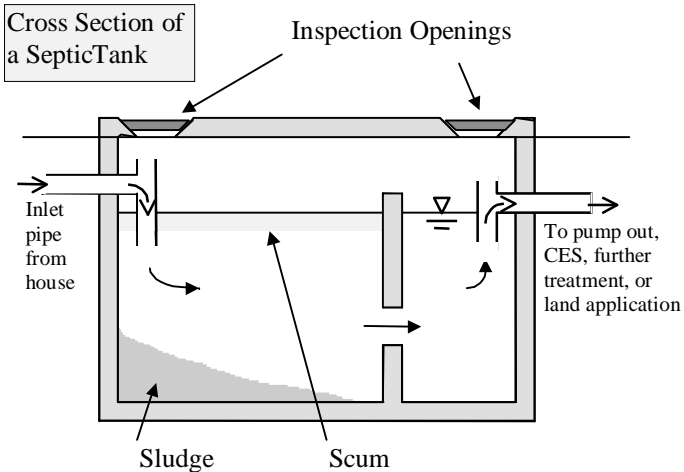

Bacteria in the septic tank break down the solid matter in the sludge and scum layers. Material that cannot be fully broken down gradually builds up in the tank and must be pumped out periodically.

There are three ways to handle septic tank effluent:

**On-site application.** The effluent flows from the septic tank to transpiration and/or absorption trenches. Here the effluent is mainly absorbed into the soil and partly evaporated by the sun and used by vegetation.

**Such application systems have the potential to contaminate groundwater and are not recommended in sensitive locations or in higher density developments. Further treatment followed by subsurface irrigation should be considered.**

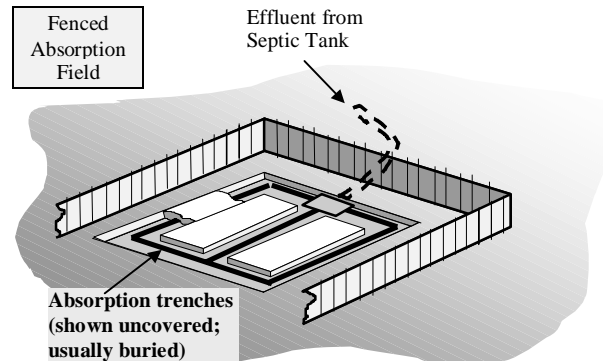

**Pump out.** The effluent flows from the septic tank into a collection well or holding tank. At regular periods, a tanker pumps out the holding tank and transports the effluent to an off-site management facility.

**Common effluent system (CES).** The treated wastewater is transported to an off-site management facility through a network of small diameter pipes.

### Regulations and recommendations

An on-site septic system requires approval from the local council before it is put in place. The regulations that apply to single household systems differ from those for multiple dwellings. The Environment Protection Authority (EPA) is responsible for approving septic tanks used to treat wastes generated by multiple dwellings like caravan parks and commercial and industrial premises. The NSW Department of Health determines the design and structural requirements for septic tanks and collection wells.

Local councils have the authority to approve systems certified by the NSW Department of Health for individual properties and ensure the systems do not have adverse impacts on health and the environment. Local councils are responsible for ensuring that the approved system is installed according to specifications and any special conditions, and is maintained and serviced correctly. You should consult your local council on the regulations that apply to you.

Care of the septic tank is only a part of the maintenance of your septic system. Management of the treated wastewater from your septic system is your responsibility and is discussed in the pamphlet "Your Land Application Area". Heavy fines may be imposed if the effluent is managed improperly.

### Maintaining your septic system

The effectiveness of the system will, in part, depend on how it is operated and maintained. The following is a guide on how to achieve the most from your system.

#### DO

- ✓ Have your septic tank desludged every three years to prevent sludge build up, which may 'clog' the pipes and absorption trenches.
- ✓ Have your septic tank serviced annually by contractors to check scum and sludge levels, and the presence of blockages in the outlet and inlet pipes.
- ✓ Have your grease trap (if installed) cleaned out at least every two months.
- ✓ Keep a record of pumping, inspections, and other maintenance.
- ✓ Learn the location and layout of your septic system and land application area.
- ✓ Check household products for suitability for use with a septic tank.
- ✓ Use biodegradable liquid detergents, such as concentrates with low phosphorous.
- ✓ Ensure your tank is mosquito-proofed.
- ✓ Conserve water.

## DON'T

- ✘ Don't put large quantities of bleaches, disinfectants, whiteners, nappy soakers and spot removers into your septic tank via the sink, washing machine or toilet.
- ✘ Don't allow any foreign materials such as nappies, sanitary napkins, condoms and other hygiene products to enter the system.
- ✘ Don't use more than the recommended amounts of detergents.
- ✘ Don't put fats and oils down the drain and keep food waste out of your system.
- ✘ Don't install or use a garbage grinder or spa bath if your system is not designed for it.

### Reducing water usage

Reducing water usage will lessen the likelihood of problems such as overloading with your septic system. Overloading may result in wastewater backing up into your house, contamination of your yard with improperly treated effluent, and effluent from your system contaminating groundwater or a nearby river, creek or dam.

Conservative water use around the house will reduce the amount of wastewater which is produced and needs to be treated.

Your septic system is also unable to cope with large volumes of water such as several showers or loads of washing over a short period of time. You should try to avoid these 'shock loads' by ensuring water use is spread more evenly throughout the day and week.

### Warning signs

You can look out for a few warning signs that signal to you that there are troubles with your septic tank. Ensure that these problems are attended to immediately to protect your health and the environment.

Look out for the following warning signs:

- 🔔 Water that drains too slowly.
- 🔔 Drain pipes that gurgle or make noises when air bubbles are forced back through the system.
- 🔔 Sewage smells, this indicates a serious problem.
- 🔔 Water backing up into your sink which may indicate that your septic system is already failing.
- 🔔 Wastewater surfacing over the land application area.

### Trouble shooting guide

If there are odours check the following areas:

- ⚠ Greasetrap (if installed), is it full or blocked?
- ⚠ Absorption field, is it wet or soggy?
- ⚠ Has there been recent heavy rain?

Odour problems from a vent on the septic system can be a result of slow or inadequate breakdown of solids. Call a technician to service the system.

### HELP PROTECT YOUR HEALTH AND THE ENVIRONMENT

Poorly maintained septic tanks are a serious source of water pollution and may present health risks, cause odours and attract vermin and insects.

By looking after your septic system you can do your part in helping to protect the environment and the health of you and your family.

If you would like more information please contact:

# Your Septic System

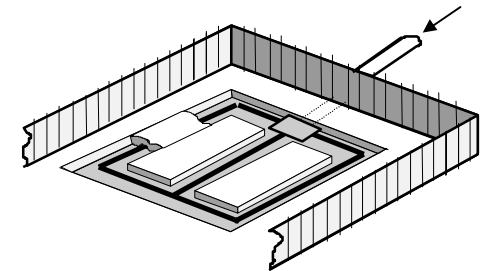
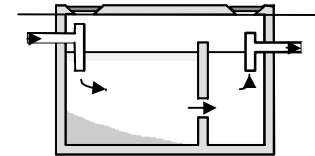

## LAND APPLICATION AREAS

The reuse of domestic wastewater on-site can be an economical and environmentally sound use of resources.

### What are land application areas?

These are areas that allow treated domestic wastewater to be managed entirely on-site.

The area must be able to utilise the wastewater and treat any organic matter and wastes it may contain. The wastewater is rich in nutrients, and can provide excellent nourishment for flower gardens, lawns, certain shrubs and trees. The vegetation should be suitably tolerant of high water and nutrient loads.

### How does a land application area work?

Treated wastewater applied to a land application area may be utilised or simply disposed, depending on the type of application system that is used. The application of the wastewater can be through a soil absorption system (based on disposal) or through an irrigation system (based on utilisation).

**Soil absorption systems** do not require highly treated effluent, and wastewater treated by a septic tank is reasonable as the solids content in the effluent has been reduced. Absorption systems release the effluent into the soil at a depth that cannot be reached by the roots of most small shrubs and grasses. They rely mainly on the processes of soil treatment and then transmission to the water table, with minimal evaporation and up-take by plants. **These systems are not recommended in sensitive areas as they may lead to contamination of surface water and groundwater.**

**Irrigation systems** may be classed as either subsurface or surface irrigation. If an irrigation system is to be used, wastewater needs to be pre-treated to at least the quality produced by an aerated wastewater treatment system (AWTS).

**Subsurface irrigation** requires highly treated effluent that is introduced into the soil close to the surface. The effluent is utilised mainly by plants and evaporation.

**Surface irrigation** requires highly treated effluent that has undergone aeration and disinfection treatments, so as to reduce the possibility of bacteria and virus contamination.

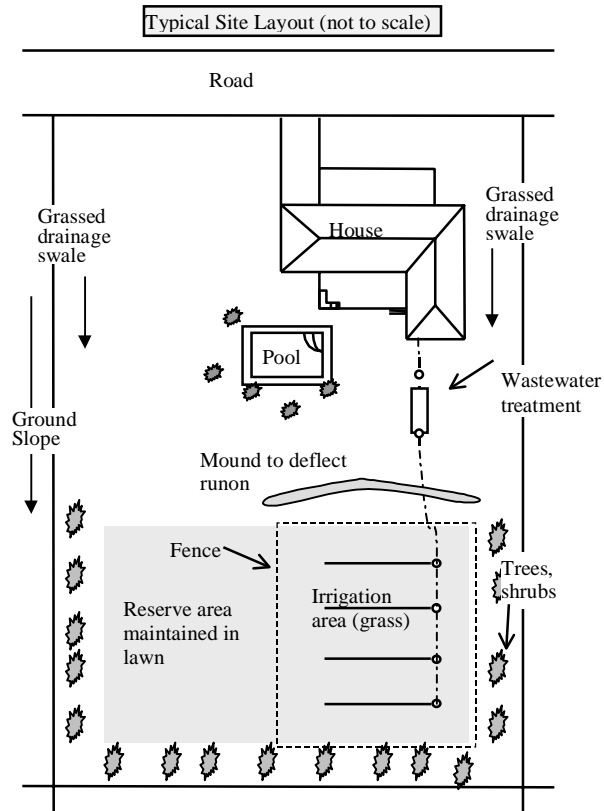

The effluent is then applied to the land area through a series of drip, trickle, or spray points which are designed to eliminate airborne drift and run-off into neighbouring properties.

There are some public health and environmental concerns about surface irrigation. There is the risk of contact with treated effluent and the potential for surface run-off. Given these problems, subsurface irrigation is arguably the safest, most efficient and effective method of effluent utilisation.

### Regulations and recommendations

The design and installation of land application areas should only be carried out by suitably qualified or experienced people, and only after a site and soil evaluation is done by a soil scientist. Care should be

taken to ensure correct buffer distances are left between the application area and bores, waterways, buildings, and neighbouring properties.

Heavy fines may be imposed under the Clean Waters Act if effluent is managed improperly.

At least two warning signs should be installed along the boundary of a land application area. The signs should comprise of 20mm high Series C lettering in black or white on a green background with the words:

**RECLAIMED EFFLUENT  
NOT FOR DRINKING  
AVOID CONTACT**

Depending on the requirements of your local council, wet weather storage and soil moisture sensors may need to be installed to ensure that effluent is only irrigated when the soil is not saturated.

Regular checks should be undertaken of any mechanical equipment to ensure that it is operating correctly. Local councils may require periodic analysis of soil or groundwater characteristics

Humans and animals should be excluded from land application areas during and immediately after the application of treated wastewater. The longer the period of exclusion from an area, the lower the risk to public health.

The householder is required to enter into a service contract with the installation company, its agent or the manufacturer of their sewage management system, this will ensure that the system operates efficiently.

### Location of the application area

Treated wastewater has the potential to have negative impacts on public health and the environment. For this reason the application area must be located in accordance with the results of a site evaluation, and approved landscaping must be completed prior to occupation of the building. Sandy soil and clayey soils may present special problems.

The system must allow even distribution of treated wastewater over the land application area.

## Maintaining your land application area

The effectiveness of the application area is governed by the activities of the owner.

### DO

- ✓ Construct and maintain diversion drains around the top side of the application area to divert surface water.
- ✓ Ensure that your application area is kept level by filling any depressions with good quality top soil (not clay).
- ✓ Keep the grass regularly mowed and plant small trees around the perimeter to aid absorption and transpiration of the effluent.
- ✓ Ensure that any run off from the roof, driveway and other impermeable surfaces is directed away from the application area.
- ✓ Fence irrigation areas.
- ✓ Ensure appropriate warning signs are visible at all times in the vicinity of a spray irrigation area.
- ✓ Have your irrigation system checked by the service agent when they are carrying out service on the treatment system.

### DON'T

- ✗ Don't erect any structures, construct paths, graze animals or drive over the land application area.
- ✗ Don't plant large trees that shade the land application area, as the area needs sunlight to aid in the evaporation and transpiration of the effluent.
- ✗ Don't plant trees or shrubs near or on house drains.
- ✗ Don't alter stormwater lines to discharge into or near the land application area.
- ✗ Don't flood the land application area through the use of hoses or sprinklers.
- ✗ Don't let children or pets play on land application areas.
- ✗ Don't water fruit and vegetables with the effluent.
- ✗ Don't extract untreated groundwater for potable use.

## Warning signs

Regular visual checking of the system will ensure that problems are located and fixed early.

The visual signs of system failure include:

- 🔔 surface ponding and run-off of treated wastewater
- 🔔 soil quality deterioration
- 🔔 poor vegetation growth
- 🔔 unusual odours

## Volume of water

Land application areas and systems for on-site application are designed and constructed in anticipation of the volume of waste to be discharged. Uncontrolled use of water may lead to poorly treated effluent being released from the system.

If the land application area is waterlogged and soggy the following are possible reasons:

- ⚠ Overloading the treatment system with wastewater.
- ⚠ The clogging of the trench with solids not trapped by the septic tank. The tank may require desludging.
- ⚠ The application area has been poorly designed.
- ⚠ Stormwater is running onto the area.

## HELP PROTECT YOUR HEALTH AND THE ENVIRONMENT

Poorly maintained land application areas are a serious source of water pollution and may present health risks, cause odours and attract vermin and insects.

By looking after your sewage management system you can do your part in helping to protect the environment and the health of you and your family.

For more information please contact:

# Your Land Application Area

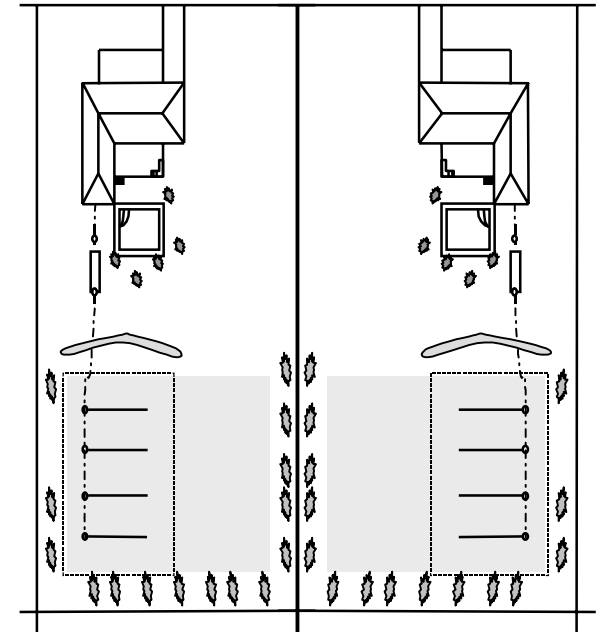

---

## GLOSSARY

**absorption:** uptake of liquid into soil

**adsorption:** increased concentration of molecules or ions on a surface, including exchangeable cations and anions on soil particles

**aerated wastewater treatment system (AWTS):** a wastewater treatment process typically involving:

- settling of solids and flotation of scum
- oxidation and consumption of organic matter through aeration
- clarification - secondary settling of solids, and
- disinfection of wastewater before surface irrigation.

**aerobic:** dissolved or free oxygen is present

**anaerobic:** dissolved or free oxygen is not present

**anaerobic digestion:** decomposition of sludge in the absence of free oxygen

**anion:** negatively charged ion; can be a single element such as chloride (Cl<sup>-</sup>) or a compound such as nitrate (NO<sub>3</sub><sup>-</sup>)

**best management practice:** those approaches that have been developed to prevent or minimise water pollution at source, or as close to the source as practicable. They include those practices determined to be the most effective and practicable ways of preventing or reducing the amount of pollution generated by non-point sources to a level compatible with water quality goals

**biochemical oxygen demand (BOD):** a measure of the dissolved oxygen required for the breakdown of organic material in the effluent; usually refers to a 5-day test (BOD<sub>5</sub>), which typically represents 70 - 80% of the total BOD in a sample; expressed in milligrams per litre (mg/L)

**biological film:** (zoogloal film) gelatinous-like film that forms on the surfaces of inert materials, forming the media in a biological filter; it can contain bacteria, protozoa and fungi, and is the site where organic matter in the wastewater is oxidised or degraded

**biosolids:** primarily organic solid product produced by wastewater treatment processes. The solids become biosolids when they come out of a digester or other treatment process and can be beneficially used. Until such solids are suitable for beneficial reuse they are defined as wastewater solids

**blackwater:** human excreta and water grossly contaminated with human excreta, for example toilet wastewater (although not strictly water-based, human excreta entering waterless composting toilets is considered as 'blackwater')

**cation:** positively charged ion; can be a single element such as potassium (K<sup>+</sup>) or a compound such as ammonium (NH<sub>4</sub><sup>+</sup>)

**cation exchange capacity (CEC):** a measure of the ability of a soil to attract and hold cations by electrical attraction; three important plant nutrients are the cations calcium ( $\text{Ca}_2^+$ ), magnesium ( $\text{Mg}_2^+$ ) and potassium ( $\text{K}^+$ )

**centralised sewerage system:** the collection of all sewer and sewerage works vested in the local authority. Usually consists of a wastewater transport system (sanitary drainage system and/or road tanker) and centralised wastewater management facility for many premises

**centralised wastewater management facility:** a facility vested in the local authority and designed for the management of wastewater and/or septage generated by many households. Examples of possible facilities are:

- package treatment plants
- full-scale sewage treatment plants
- biosolids management facilities
- effluent re-use facilities
- effluent discharge facilities

**compost:** the material produced by the aerobic biological decomposition of the organic constituents of a material

**constructed wetland:** constructed area where the water surface is near ground level for enough of the year to maintain saturated soil conditions and promote related vegetation

**denitrification:** transformation of nitrate into the gaseous  $\text{NO}$  and  $\text{N}$  forms; denitrification is an anaerobic process carried out by micro-organisms; it can occur only if the soil becomes oxygen deficient (for example, as a result of waterlogging)

**desludging:** withdrawing sludge, scum and liquid from a tank

**disinfection:** a process that destroys, inactivates or removes pathogenic micro-organisms

**domestic wastewater:** wastewater arising from household activities, including wastewater from bathrooms, kitchens and laundries

**electrical conductivity (EC):** an electrical measure of the concentration of salts in solution; the salts that occur in significant amounts in domestic wastewater are the chlorides, sulphates and bicarbonates of sodium, potassium, calcium and magnesium; in water these salts dissociate into charged ions and the EC of the solution is proportional to the concentration of these ions. The units of EC are deciSiemens per metre (dS/m) at 25°C

**equivalent population:** a measure typically used in the design of wastewater management systems. Because there are differences in wastewater generation rates between premises with and without reticulated water supplies, and premises with dry composting toilet technologies, it is usually easier to stipulate design limits by an 'equivalent' number of people rather than the total flow

**evapotranspiration:** removing water from soil by evaporation and from plants by transpiration

**faecal coliforms (fc):** a type of bacteria that live only in the gut of warm-blooded animals. Can be detected in the general environment if that environment is contaminated with human excreta, and therefore can act as an indicator of recent faecal contamination



**greywater:** (sullage) domestic wastewater, excluding toilet waste

**groundwater:** all underground waters

**human excreta:** human faeces and urine

**human waste storage facility (HWSF):** device for holding or disposing of human waste, including a cesspit, chemical closet and pan toilet. (from the *Local Government Act 1993*)

**human waste treatment device (HWTd):** device for treating human excreta and other wastewater, including a septic tank, aerated wastewater treatment system, septic closet, water closet, humus closet and combustion closet (from the *Local Government Act 1993*)

**hydraulic loading rate (hydraulic load, hydraulic loading):** the amount of liquid applied to land over a specified time interval. Can be expressed as either a depth or a volume (with one millimetre of application equal to one litre per square metre)

**land application area:** the area over which treated wastewater is applied

**land application system:** system that can consist of pumps, pipes, nozzles, or trenches designed to apply wastewater evenly over a land application area. Includes both irrigation systems and soil absorption systems

**landform element:** an area with a definable slope, toposequence, position, and land surface features. Landform elements typically have characteristic dimensions of greater than 40 metres and less than 600 metres diameter. Examples are hillcrests, footslopes, swales and levees. Seventy types of landform element are described in Speight, J G (1990)

**local authority:** examples are:

- licence regulators in metropolitan areas
- local councils in country NSW
- water boards established for specific locations

**nitrification:** transformation of inorganic ammonium ( $\text{NH}_4^+$ ) into nitrate ( $\text{NO}_3^-$ )

**nutrients:** chemical elements that are essential for sustained plant or animal growth; the major nutrients essential for plant growth are nitrogen, phosphorus and potassium; in excess, nitrogen and phosphorus are potentially serious pollutants encouraging nuisance growths of algae and aquatic plants in waters and (in the case of nitrate) posing a direct human health risk

**organic matter:** material consisting of chemical compounds based upon carbon skeletons (proteins, carbohydrates and fats); may be present in dissolved, suspended and colloidal form; it is usually measured as BOD in a liquid

**organic matter loading:** the amount of organic matter applied to land over a specified time interval. The amount of organic material in effluent is usually expressed as BOD

**partial on-site sewage management (partial on-site management):** the preliminary treatment of wastewater on-site, followed by management in a centralised sewerage system

**pathogens:** micro-organisms that are potentially disease-causing; these include but are not limited to bacteria, protozoa and viruses

**percolation:** the descent of water through the soil profile

**permeability:** the general term used to describe the rate of water movement through a soil

**pH:** a measure of hydrogen ion concentration. It is an indicator of acidity or alkalinity and ranges from 0 - 14, where 0 is the most acid, 14 the most alkaline, and 7 neutral

**potable:** water of a quality suitable for drinking and domestic use that does not deteriorate on storage and that does not contain pathogenic organisms

**precipitation:** deposits of water, either in liquid or solid form, that reach the earth from the atmosphere

**recirculating aerobic sand filter device (RASFD):** (intermittent sand filter) provides further treatment of pre-treated wastewater by percolation through graded sand

**recurrence interval:** (in these guidelines) a statistical average time between events

**regolith:** loose, incoherent fragments of soil, alluvium, etc. which rests upon solid rock

**residual chlorine:** chlorine remaining in solution after a specified period of contact between the solution and the chlorine

**reticulated water supply:** the provision by a water authority of water for potable and non-potable uses to households through a network of pipes

**run-off:** the part of the precipitation and/or irrigated effluent that becomes surface flow because it is not immediately absorbed into or detained on the soil

**run-on:** surface water flowing on to an irrigation area as a result of run-off occurring higher up the slope

**sanitary drainage system:** an assembly of pipes, fittings and apparatus used to collect the discharge from the sanitary plumbing system and convey it to a centralised wastewater management facility

**sanitary plumbing system:** an assembly of pipes, fittings, fixtures and appliances used to collect wastewater from household drains and convey it to the sanitary drainage system

**scum:** material that collects at the top of primary wastewater treatment tanks, including oils, grease, soaps and plastics

**septage:** material pumped out from septic tanks during desludging; contains partly decomposed scum, sludge and liquid

**septic tank:** wastewater treatment device that provides a preliminary form of treatment for wastewater, comprising sedimentation of settleable solids, flotation of oils and fats, and anaerobic digestion of sludge

**septic wastewater:** wastewater that contains no dissolved oxygen; it is black, has a foul odour, and contains high numbers of pathogenic organisms

**sewage:** waste matter which passes through sewers. Sewage includes any effluent of a kind referred to in paragraph (a) of the definition of *waste* in the Local Government Act.

**sewage management:** any activity carried out for the purpose of holding or processing, or re-using or otherwise disposing of, sewage or by-products of sewage.

**sludge:** mainly organic semi-solid product produced by wastewater treatment processes

**soil absorption system:** (includes leach drains, drain fields, absorption trenches, seepage beds and seepage pits) subsurface land application systems that rely on the capacity of the soil to accept and transmit the applied hydraulic load

**split system:** wastewater management system in which a septic tank accepts waste directly from the toilet and kitchen, and treated wastewater is directed to a land application area. The remainder of the wastes are drained to another land application area through a sullage tank or greywater treatment system

**suspended solids (SS):** in wastewater analysis: solids retained after filtration through a glass fibre filter paper followed by washing and drying at 105°C, or by centrifuging followed by washing and removal of the supernatant liquid; expressed in milligrams per litre (mg/L)

**total off-site sewage management (total off-site management):** management of untreated domestic wastewater in a centralised sewerage system

**total on-site sewage management (total on-site management):** treatment and use of all wastewater generated within a household, completely within the boundary of the premises

**treated wastewater:** (in these guidelines) wastewater that has received treatment via a human waste treatment device

**vectors:** insects or animals, such as flies, mosquitos or rodents, that are attracted to the putrescible organic material in wastewater and wastewater treatment systems, and that spread disease

**waterless composting toilet:** (humus closet, biological toilet) waterless system that uses the principle of composting to break down human excreta to a humus-type material. The liquid fraction is evaporated or directed to an appropriate management system

**wet composting toilet:** treats all household wastewater and putrescible household organic solid wastes such as food waste. Uses the principle of aerobic composting to break down the solid waste; the liquid component is directed to a land application system after passing through the pile of solids

## BIBLIOGRAPHY

ANZECC 1992, *National Water Quality Management Strategy*, Australian and New Zealand Environment & Conservation Council, Canberra

Auckland Regional Council 1994, *On-site Wastewater Disposal from Households and Institutions*, Auckland Regional Council, New Zealand

Australian Water Resources Council 1988, *Water Management Series No. 14: Low Cost Sewerage Options Study*, Department of Primary Industries and Energy, Australia

Australian Water Resources Council 1988, *Water Management Series No. 14: Low Cost Sewerage Options Study*.

Bannerman S M & Hazelton P A (eds) 1991, *Training Course in Soil Technology and Applied Soil Science*, University of Sydney Union, Sydney

Bouma J 1979, 'Subsurface Application of Sewage Effluent', in *Planning the Uses and Management of Land*, chapter 27, Agron Series 21, Am. Soc. Agron., Crop Sci. Soc. Am., Soil Sci. Soc. Am., Madison, USA

Brouwer J & Bugeja R M 1983, *Land Capability for Septic Tank Effluent Absorption Fields*, Department of Resources and Energy, Australian Water Resources Council, Australian Government Publishing Service, Australia

Charman P E V & Murphy B W (eds) 1991, *Soils - Their Properties and Management. A Soil Conservation Handbook for NSW*, Soil Conservation Commission of NSW, Sydney

Christiansen J E & Hargreaves G H 1969, *Irrigation Requirements from Evaporation*, Proc. 7th Congress on Irrigation and Drainage, International Commission on Irrigation and Drainage

Collins, E. 1994, *On-Site Wastewater Treatment - Proceedings of the Seventh International Symposium on Individual and Small Community Sewage Systems*, 11-13 December 1994, Atlanta Georgia, by American Society of Agricultural Engineers, Michigan, U.S.

Commonwealth of Australia 1992, *National Strategy for Ecologically Sustainable Development*, Australian Government Publishing Service, Canberra

DLWC 1996, *Country Towns Water, Sewerage and Drainage Program: Technical and Financial Assistance to Councils*, NSW Department of Land and Water Conservation, Sydney, Australia

DLWC 1997a, *Environmental Management Guidelines for Local Government Water Supply, Sewerage and Drainage Services*, NSW Department of Land and Water Conservation, Sydney Australia

DLWC 1997b, *Draft NSW Groundwater Quality Protection Policy*, NSW Department of Land and Water Conservation, Sydney, Australia

DUAP - SCMCC 1996, *Incorporating the Principles of TCM into Land Use Planning*, NSW Department of Urban Affairs and Planning - NSW State Catchment Management Coordinating Committee, Sydney

Gunn R H, Baettie J A, Reid R E & van de Graaff R H M, 1988, *Australian Soil and Land Survey Handbook - Guidelines for Conducting Surveys*, Inkata Press, Australia

Hazelton P A & Murphy B W (eds) 1992, *What Do All the Numbers Mean? A Guide for the Interpretation of Soil Test Results*, Department of Conservation and Land Management (incorporating the Soil Conservation Service of NSW), Sydney

Hoxley G and Dudding M 1994, 'Groundwater Contamination By Septic Tank Effluent: Two Case Studies in Victoria, Australia', *Water Down Under 94*, Proceedings of the 25th Congress of the International Association of Hydrogeologists and the International Hydrology & Water Resources Symposium of The Institution of Engineers, Australia, November 1994, Adelaide

Kruger I et al (eds) 1995, *Australian Pig Housing Series, Effluent at Work*, NSW Agriculture, Australia

Local Government and Shires Association of NSW 1995, *Social Impact Assessment for Local Government: A Hand Book for Councillors, Town Planners and Social Planners*. Jointly published with NSW Government Social Policy Directorate, Australia.

Martens D M & Correy B 1992, *On-site Domestic Aerobic Wastewater Treatment: Process and Design*, Australia

Martens D M & Warner R F 1991, *Evaluation of the Environmental Impacts of Aerated Wastewater Treatment Systems*, University of Sydney, Sydney

McClelland, N.I., and Evans, J.L. (Ed.) 1981, *Individual Onsite Wastewater Systems - Proceedings of the Seventh National Conference*, 23-25, September, 1980, by National Sanitation Foundation, Michigan, U.S.

McDonald R C, Isbell R F, Speight J G, Walker J & Hopkins M S 1990, *Australian Soil and Land Survey Field Handbook*, Inkata Press, Australia

NSW Environment Protection Authority 1995, *Draft Environmental Guidelines for Industry: The Utilisation of Treated Effluent by Irrigation*, NSW EPA, Sydney

NSW Environment Protection Authority 1997, *Environment Management Guidelines for the Use and Disposal of Biosolids Products*, NSW EPA, Sydney

NSW Public Works 1993, *Strategic Business Plans for Water Supply and Sewerage Schemes - Guidelines for Preparation*, PWD Report No. 93085, Australia.

O'Neill R A, Roads G K & Wiese R N 1993, *On-Site Wastewater Treatment and Disposal in NSW*, UTS, Sydney

Petrozzi M & Martens D M 1995, *On-site Sewage Treatment Options: A Discussion Paper on the Environmental and Health Ramifications of On-site Domestic Wastewater Treatment and Disposal Options*, Martens & Associates, Sydney, Australia

- Queensland Department of Natural Resources and NSW Health 1997, *On-Site Wastewater Treatment Systems - 2nd National Workshop*, Sydney, 13-14, March, 1997
- Queensland Department of Primary Industries - Water Resources and NSW Health 1995, *On-Site Sewage Treatment Plants - National Workshop*, Sydney 11-12, May 1995
- Rawlinson L 1994, *Review of On-site Wastewater Systems*. NSW EPA, Sydney.
- Rayment G E & Higginson F R 1992, *Australian Laboratory Handbook of Soil and Water Chemical Methods*, Inkata Press, Melbourne
- Reed S C, Crites R W, and Middlebrooks E J 1988, *Natural Systems for Waste Management and Treatment*, McGraw-Hill, Sydney
- South Australian Health Commission 1994a, *Standard for the Installation and Operation of Septic Tank Systems in South Australia*, South Australian Health Commission, Adelaide
- South Australian Health Commission 1994b, *Standard for the Installation and Operation of Septic Tank Systems in South Australia, Supplement A - Guidelines and Construction Requirements for Aerobic Sand Filters of Up to 50m<sup>2</sup> Top Surface Contact Area*, South Australian Health Commission, Adelaide
- South Australian Health Commission 1994c, *Standard for the Installation and Operation of Septic Tank Systems in South Australia, Supplement B - Guidelines for the Installation and Operation of Aerobic Wastewater Treatment Systems*, South Australian Health Commission, Adelaide
- Speight JG 1990, *Landform in Australian Soil and Land Survey Field Handbook*, Inkata Press, Melbourne
- Standards Australia 1990, *AS1546 - 1990 Small Septic Tanks*, Standards Australia, Sydney, Australia
- Standards Australia 1994, *AS/NZS 9000 Series: Quality management and quality assurance standards*, Standards Australia and Standards New Zealand, Sydney, Australia
- Standards Australia 1995, *Draft AS1547 Disposal Systems for Effluent from Domestic Premises*, Standards Australia, Sydney, Australia (or latest available version)
- Tchobanoglous G & Burton F L 1991, *Wastewater Engineering: Treatment, Disposal, and Reuse*, 3rd edn, Metcalf and Eddy Inc, McGraw Hill, New York.
- USEPA 1980, *Design Manual: Onsite Wastewater Treatment and Disposal Systems*, EPA - 625/1 - 80 - 012, US Environmental Protection Agency, Washington DC
- USEPA 1992, *Manual for Wastewater Treatment/Disposal for Small Communities*, EPA/ 625R - 92/005, US Environmental Protection Agency, Washington DC
- USEPA 1994, *Environmental Planning for Small Communities, A Guide for Local Decision-Makers*, EPA/625/r-94/009 Office of Research and Development, Washington, D.C. U.S.
- UWRAA and ARMCANZ 1997, *Handbook on Affordable Water Supply and Sewerage for Small Communities*, Urban Water Research Association of Australia and Agriculture and Resource Management Council of Australia and New Zealand

## FURTHER INFORMATION

### NSW EPA OFFICES

ALBURY  
ph:(02) 6041 4963

ARMIDALE  
ph:(02) 6773 7133

BANKSTOWN  
ph: (02) 9795 5000

BATHURST  
ph:(02) 6332 1838

BURONGA  
ph:(03) 5022 1096

CHATSWOOD  
ph:(02) 9325 5555

DUBBO  
ph:(02) 6882 9011

GOSFORD  
ph:(02) 4323 9865

GRAFTON  
ph:(02) 6642 0535

GRIFFITH  
ph:(02) 6964 1880

MOREE  
ph:(02) 6751 1519

MURWILLUMBAH  
ph:(02) 6672 6134

MUSWELLBROOK  
ph:(02) 6542 5016

NEWCASTLE  
ph:(02) 4926 9971

PENRITH  
ph:(02) 4721 3700

QUEANBEYAN  
ph:(02) 6299 3330

WYONG  
ph:(02) 4352 2762

WOLLONGONG  
ph:(02) 4226 8100

## NSW HEALTH – PUBLIC HEALTH UNITS

### CENTRAL SYDNEY

(Camperdown)

**ph:(02) 9515 3180**

### NORTHERN SYDNEY

(Hornsby)

**ph:(02)9477 9400**

### SOUTH EASTERN SYDNEY

(Zetland)

**ph:(02) 9313 8322**

### SOUTH WESTERN SYDNEY

(Liverpool)

**ph:(02) 9828 5944**

### WESTERN SYDNEY AND WENTWORTH

(North Parramatta)

**ph:(02) 9840 3603**

### ALBURY

(Albury)

**ph:(02) 6021 4799**

### BROKEN HILL

(Broken Hill)

**ph:(02) 8088 0446**

### CENTRAL COAST

(Wyoming)

**ph:(02) 4320 4545**

### HUNTER

(Wallsend)

**ph:(02) 4924 6477**

### ILLAWARRA

(Gwynneville)

**ph:(02) 4226 4677**

### MID NORTH COAST

(Port Macquarie)

**ph:(02) 6583 0716**

### MID WESTERN NSW

(Bathurst)

**ph:(02) 6332 8505**

### NEW ENGLAND

(Tamworth)

**ph:(02) 6766 2288**

### NORTHERN RIVERS

(Lismore)

**ph:(02) 6620 7500**

### SOUTHERN NSW

(Goulburn)

**ph:(02) 4827 3428**

Wagga Wagga Office

**ph:(02) 6938 6402**

### WESTERN NSW

(Dubbo)

**ph:(02) 6881 2216**



## DEPARTMENT OF LAND AND WATER CONSERVATION REGIONAL OFFICES

BARWON REGION  
(Tamworth)  
**ph:(02) 6766 3711**

MURRAY REGION  
(Deniliquin)  
**ph:(03) 5881 2122**

CENTRAL WEST REGION  
(Orange)  
**ph:(02) 6363 8278**

MURRUMBIDGEE REGION  
(Wagga Wagga)  
**ph:(02) 6923 0475**

FAR WEST REGION  
(Dubbo)  
**ph:(02) 6883 3000**

NORTH COAST REGION  
(Grafton)  
**ph:(02) 6643 2822**

HUNTER REGION  
(East Maitland)  
**ph:(02) 4934 1055**

SYDNEY SOUTH COAST REGION  
(Wollongong)  
**ph:(02) 4226 8563**

## DEPARTMENT OF URBAN AFFAIRS AND PLANNING REGIONAL OFFICES

NORTHERN REGIONS  
(Grafton)  
**ph:(02) 6642 0622**

SOUTHERN AND WESTERN  
REGION  
(Queanbeyan and Sydney)  
**ph:(02) 6297 6911**

HUNTER AND CENTRAL COAST  
REGION  
(Newcastle)  
**ph:(02) 4926 2566**

**ph:(02) 9391 2000**

SYDNEY REGION WEST  
(Parramatta)  
**ph:(02) 9895 7633**

ILLAWARRA / MACARTHUR  
REGION  
(Wollongong)  
**ph:(02) 4226 8120**

SYDNEY REGION NORTH  
(Sydney)  
**ph:(02) 9391 2000**

SYDNEY REGION SOUTH  
(Rockdale)  
**ph:(02) 9597 1233**

## OTHER SOURCES OF INFORMATION

### AWTS MANUFACTURERS ASSOCIATION

PO Box R16  
RHODES NSW 2138  
**Ph & Fax:(02) 9743 3063**

### AUSTRALIAN INSTITUTE OF ENVIRONMENTAL HEALTH

PO Box 384  
DRUMMOYNE NSW 2047  
**Ph:(02) 9719 8933**  
**Fax:(02) 9719 8251**

### AUSTRALIAN PLANTS SOCIETY

BLACKTOWN NSW  
**Ph:(02) 9621 3437**

### AUSTRALIAN SOCIETY OF SOIL SCIENCE INC.

1/F 91 Rathdowne Street  
CARLTON VIC 3053  
**Ph:(03) 9662 1520**  
**Fax:(03) 9662 2727**

### AUSTRALIAN WATER & WASTEWATER ASSOCIATION

PO Box 3888  
ARTARMON NSW 2064  
**Ph:(02) 9413 1288**  
**Fax:(02) 9413 1047**

### BUILDING SERVICE CORPORATION

Department of Fair Trading  
Australian Wheat Board House  
Level 12, 234 Sussex Street  
SYDNEY NSW 2000  
**Ph:(02) 9377 9310**  
**Fax:(02) 9377 9385**

### CENTRE FOR NATURAL RESOURCES

Soil Data System Coordinator  
Department of Land & Water Conservation  
GPO Box 39  
SYDNEY NSW 2001  
**Ph:(02) 9228 6348**  
**Fax:(02) 9228 6519**

### ENVIRONMENTAL ENGINEERS SOCIETY

**The Institution of Engineers Australia**  
Sydney Division  
118 Alfred Street Milsons Point NSW 2061  
**Ph:(02) 9929 8544**  
**Fax:(02) 9956 7670**

### ORGANIC WASTE RECYCLING UNIT

NSW Agriculture  
Locked Bag 4  
RICHMOND NSW 2753  
**Ph:(045) 78 2666**  
**Fax:(045) 78 2528**

### SOIL SURVEY UNIT

Department of Land & Water Conservation  
PO Box 3720  
PARRAMATTA NSW 2124  
**Ph:(02) 9895 6172**  
**Fax:(02) 9895 7985**

Various catchment Management Committees or Trusts, contact:

### **State Catchment Management Coordinating Committee**

Department of Land & Water Conservation  
GPO Box 39  
SYDNEY NSW 2001  
**Ph:(02) 9228 6171**  
**Fax:(02) 9228 6457**

## On-Site Sewage Management Guidelines - Errata

The following *errata* have been issued for the **Environment and Health Protection Guidelines: On-Site Sewage Management for Single Households**

Amendment 1 (20 July, 1999)  
Page 68, Table 6 - Soil Assessment.  
Amend last row of the table to read:

Soil Feature	Relevant System(s)	Minor Limitation	Moderate Limitation	Major Limitation	Restrictive Feature
Modified Emerson Aggregate Test (dispersiveness)	All land application systems	<b>Class 3,4</b>	Class2	<b>Class 1</b>	Potential for structural degradation

Amend note 1 to read:

1. Sites with these properties are generally **not** suitable or require specialised design

Amendment 2 (25 January, 2001)  
Page 145, Appendix 2 - Model Site Report  
Amend 11<sup>th</sup> row of Part 3 Site Assessment to read:

<p><b>Groundwater</b> Horizontal distance to groundwater well used for domestic water supply (m) Relevant groundwater vulnerability map referred to? yes / no / not available<sup>1</sup> Level of Protection (I – V)<sup>2</sup> Bores in the area and their purpose:</p>
--

Insert the following explanatory notes at the end of the Model Site Report (p.147).

**Notes:**

1. If vulnerability maps are not available within a certain catchment, advice should be sought from the relevant local DLWC groundwater professionals.
2. Assessment Requirement for Groundwater Protection

Groundwater vulnerability maps do not consider the nature or potential impact of pollutants when classifying vulnerability. They are concerned with the hydro-geologic setting which makes groundwater susceptible to contamination from a surface source. The assessment and management requirements for areas of different vulnerability are:

Class I - Low

*Groundwater Contamination Assessment Report*

A desk study is required to identify the concerns and potential risk to groundwater or the environment and the need for any further action to be presented in the development application. A standard format hydrogeologic report would most likely result.

Class II - Low-Moderate

*Site Investigation With Monitoring*

A potential risk is indicated by the vulnerability map requiring site investigation and groundwater monitoring. The extent of work should involve a limited amount of site investigation, soil and water sampling and testing, definition of flow systems and reporting, in addition to a desk study.

Class III - Moderate

*Detailed Site Investigation and Monitoring*

For moderate vulnerability areas, or where the previous levels of investigation indicate a demonstrated risk to groundwater, a detailed groundwater site investigation is required. The work should include an ongoing monitoring program, details on the protection design factors, (natural attenuation, physical barriers, etc) in addition to the previous levels of investigation.

Class IV - Moderately High

*Demonstrated Groundwater Protection System*

The risk to groundwater, as demonstrated by the vulnerability map, is an area in which contamination to groundwater cannot be tolerated. The work should include a desk study, detailed site investigation, and implementation of an on-going monitoring program, as indicated above. In addition, the protection design system incorporating natural attenuation, hydraulic barriers, physical barriers etc, needs to be demonstrated, to be effective. The proposal will need to include a feasibility plan for a clean-up, in addition to a detailed monitoring and ongoing assessment program.

Class V - High

*Demonstrated Remedial Action Plan/Prohibition*

This classification identifies the area as having a potential risk so great as to warrant a demonstrated remedial action plan. The work should include a desk study, site investigations, ongoing monitoring, plus a demonstrated remedial action plan for clean-up, which analyses the effectiveness of the remediation approach in achieving designated water quality criteria. The financial capacity of the responsible party to enact the plan should also be evaluated. In the event that the risk to groundwater is unacceptable, an activity may be banned by the responsible authority.

## Using the Onsite Sewage Management Guidelines

### Application of Appendix 6 (Estimating Irrigation Areas & Wet Weather Storage)

Appendix 6 provides a discussion on the estimation of irrigation area and wet weather storage requirements for ecologically sustainable sewage management. As is noted (p.152) the issues are complex and there is no "correct" or "right" answer. The worked example is a possible approach for consideration by councils and consultants. The example is considered appropriate because of its relative simplicity, and because it should allow an appreciation of the problems inherent in applying models to complex situations. It is not expected that councils should universally apply the methodology outlined.

**The discussion in Appendix 6 does not preclude the use of other approaches to wastewater management and sewage management system design.** Appendix 6 demonstrates that achieving the performance standards of the sewage management regulation requires careful consideration of nutrient and hydraulic loading. Alternative approaches can be used but system design should take into account the site and soil constraints specific to the site, and be carried out by qualified people aware of relevant work in this area. The purpose of is to ensure that any sewage management facilities are able to comply with the performance standards and will be consistent with the principles of ecological sustainability.

### Wet Weather Storage

Wet weather storage is one option for maintaining an acceptable water balance in higher rainfall areas. However increased storage of effluent on site can create additional health risk and management problems. In domestic applications all other practical water conservation and effluent management options should be considered before requiring wet weather effluent storage facilities. Some options are listed on pp 132-133 of the Guidelines. Where wet weather storage is deemed necessary in particular cases, special consideration should be given to the management of storage tanks and associated pumping facilities.

### Soil Testing for Single Sites

The purpose of soil testing is to obtain useful information about the soil/water dynamics of a site, to enable appropriate site selection, and to inform design and assessment of an ecologically sustainable sewage management system. The Guidelines recommend (p. 69) that basic soil testing should be carried out for single sites where more comprehensive analysis has been carried out at subdivision stage. The purpose of this assessment is to confirm constraints and to allow appropriate design adjustments to be made.

The Guidelines do not specify a recommended soil testing regime for single dwellings on sites where a subdivision assessment was not previously prepared. (Note: The Guidelines focus on new development on land that has not previously been subdivided - see p.9) The appropriate soil capability assessment for sewage facilities on existing subdivisions is a matter for the council to determine. The assessment should at least identify major constraints, and by informed site inspection determine the likely soil/water dynamics. Such site assessments can be carried out by any person the council

considers qualified to identify and report on constraints which would prevent the proposed sewage management system being able to comply with performance standards. This assessment may be carried out by a council environmental health officer with appropriate training.

**Garry Payne**  
**Director General**